

# *The Infinity Clock*

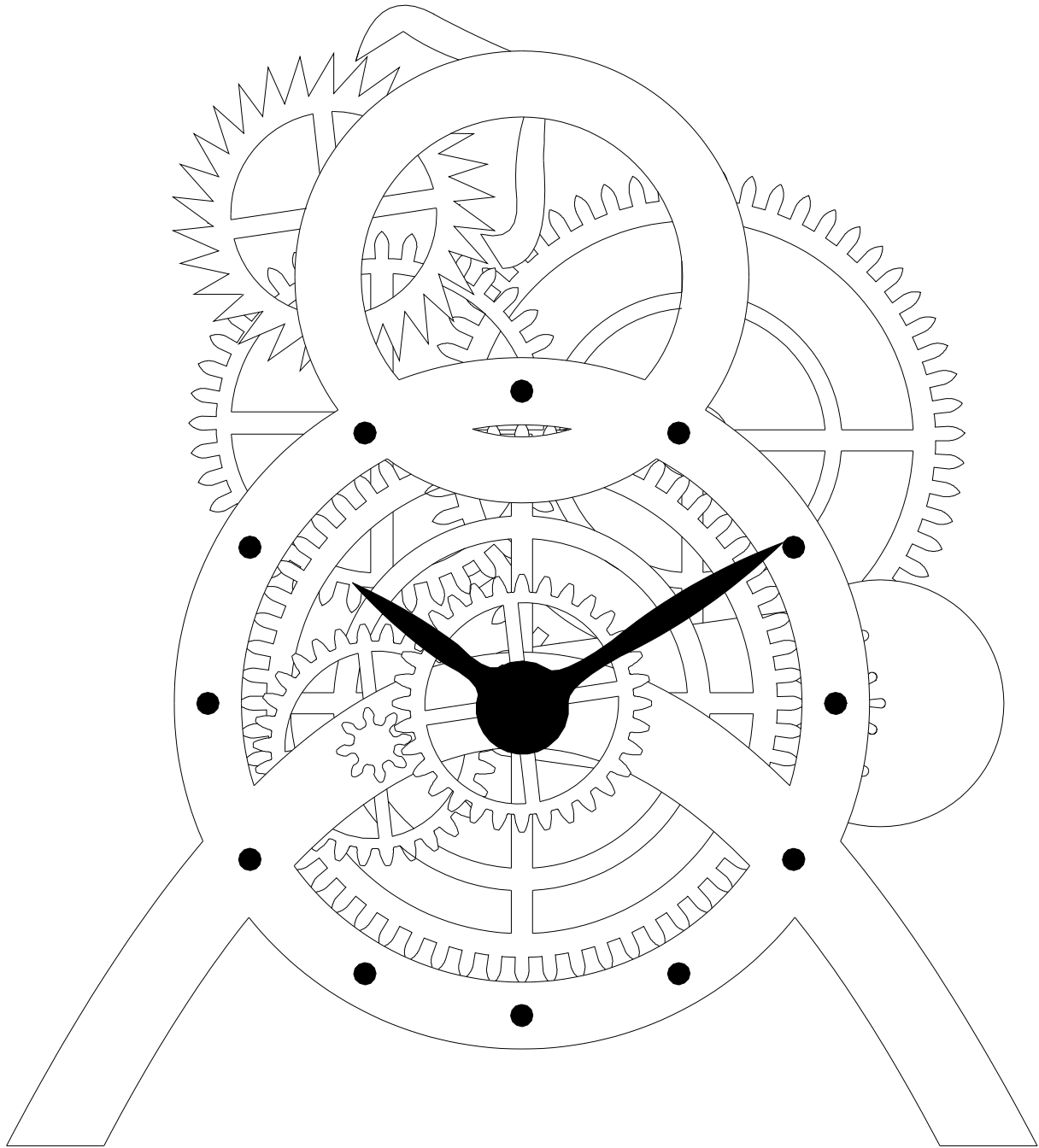

Copyright © 2026  
Jeffrey A. Schierenbeck

Wooden  Clocks

# Introduction

For centuries, mechanical clocks have served as functional timekeepers. During that time, clocks have also been treasured for their artistic and aesthetic value. For most clocks, the artistry involves the shape and ornamentation of the clock's exterior case. However, these cases hide the inner beauty of the clock—the clockwork mechanism.

The Infinity clock is a wooden gear clock that is a functional timekeeper with an open frame which exposes its mechanical elements. All the moving parts are clearly visible. It is intriguing to watch as the seconds and minutes tick away. This clock features a unique drive mechanism: a weighted arm applies a torque to the gear train. A battery powered motor, triggered by a tilt switch, resets (raises) the arm so the clock runs continuously until the batteries drain.

It is enjoyable to see and hear this clock running. However, the most enjoyable part of this clock is the satisfaction gained by assembling the clock yourself, perhaps adding your own creative touches. And, through the process of building the clock, you will gain an understanding of the principles that govern how a clock works.

We truly hope you enjoy building your clock. Please contact us if there is any way that we can help you with your clockmaking project.

## Tools and Supplies

The following items will be necessary to build your clock:

- Phillips screwdriver
- pliers
- wire cutters or needlenose pliers
- hammer
- clamps (small spring clamps work well)
- wood glue
- CA glue (“Superglue”)
- sandpaper (150 grit, 220 grit, 400 or 600 grit suggested)
- pencil
- lighter or heat gun
- toothpicks
- ruler or measuring tape
- two wood blocks (2x4 or 4x4 scraps, 6-12" long)
- 4 AA batteries (not included - Energizer or Duracell recommended)

## Safety

It is your responsibility to use the proper tools and techniques to accomplish this project. Consult the owner's manuals and label directions for any tools or products used in completing this project.

This package contains small parts, and should be kept away from young children.

## Copyright

The Infinity clock kit, manual, and patterns are protected by US copyright law. All rights reserved.

# Assembly Tips

- 1) To remove precut parts from the original board, carefully bend the parts back and forth to break the small sliver of wood that is holding them in place. **Remove pieces as needed rather than all at once.**
- 2) You can stain your clock if desired. If you are working from a kit with contrasting wood species, it really isn't necessary to stain the wood. Although not needed, you might want to apply a clear finish such as spray lacquer. Since a finish can hinder glue bonding, wait to apply any finish until the components have been glued together. **If using a film finish such as polyurethane, avoid applying it to the contact faces of the gear teeth.** If applying a finish, remove the parts from the blank before applying finish.
- 3) A few components require gluing. Glued parts should be clamped while the glue cures. Be careful that the parts do not slide under clamping pressure (it might help to wait a few minutes to let the glue 'tack up' before applying the clamps).
- 4) Follow the instructions in order. Carefully complete one step before moving on to the next step.
- 5) Some laser-cut pieces might benefit from some light sanding, especially at the breakaway points where the pieces were attached to the original board. **Do not sand the mating surfaces of the gear teeth.** Note that the backsides of some pieces may show residue from the laser cutting operation. A light sanding will remove this residue. However, this should not be necessary because the residue will not be visible once the clock is assembled. If desired, the edges of the non-gear pieces can be sanded to remove the residue left by the laser.
- 6) Some of the parts fit tightly together. It may be necessary to gently tap them together with a hammer. If the fit seems too tight, some light sanding may be necessary to insure a proper fit.
- 7) Once the clock is assembled, some adjustments may be required to get the clock running properly. Follow the suggestions found in the "Regulating and Adjusting" and the "Troubleshooting" sections of these instructions.
- 8) A duplicate copy of the part list is included on the last page of this manual. Remove this page from the manual so that it can be easily referred to during assembly.
- 9) QR codes are included near some steps. Scan these to watch a video of that assembly step being performed.
- 10) Take your time and enjoy the process! Please contact us if you have any questions during assembly.

# Part List

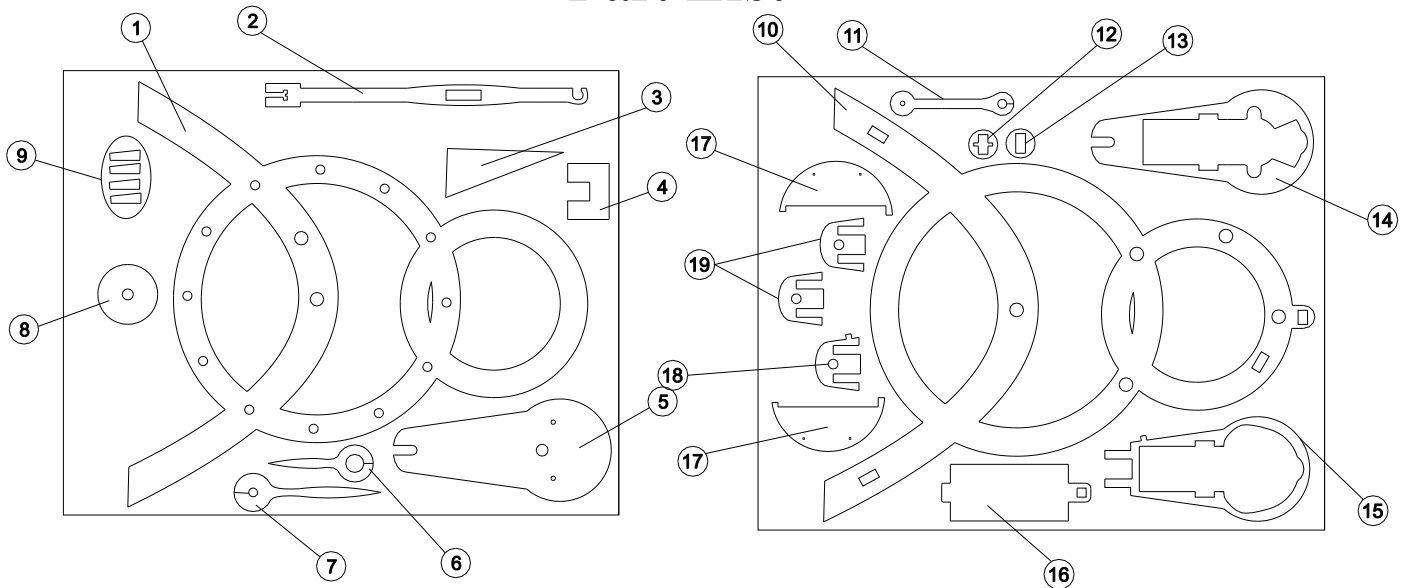

- |                            |                             |                                    |
|----------------------------|-----------------------------|------------------------------------|
| 1. Front frame front piece | 7. Minute hand (frame wood) | 13. Tilt switch holder bottom      |
| 2. Pendulum shaft          | 8. Gear staking jig         | 14. Weight arm back                |
| 3. Squaring jig            | 9. Wedges [3]               | 15. Weight arm second layer        |
| 4. Pillar jig              | 10. Rear Frame              | 16. Pillar [3]                     |
| 5. Weight arm veneer piece | 11. Crutch arm              | 17. Pendulum bob middle [2]        |
| 6. Hour hand (frame wood)  | 12. Tilt switch holder top  | 18. Weight arm end middle piece    |
|                            |                             | 19. Weight arm end outer piece [2] |

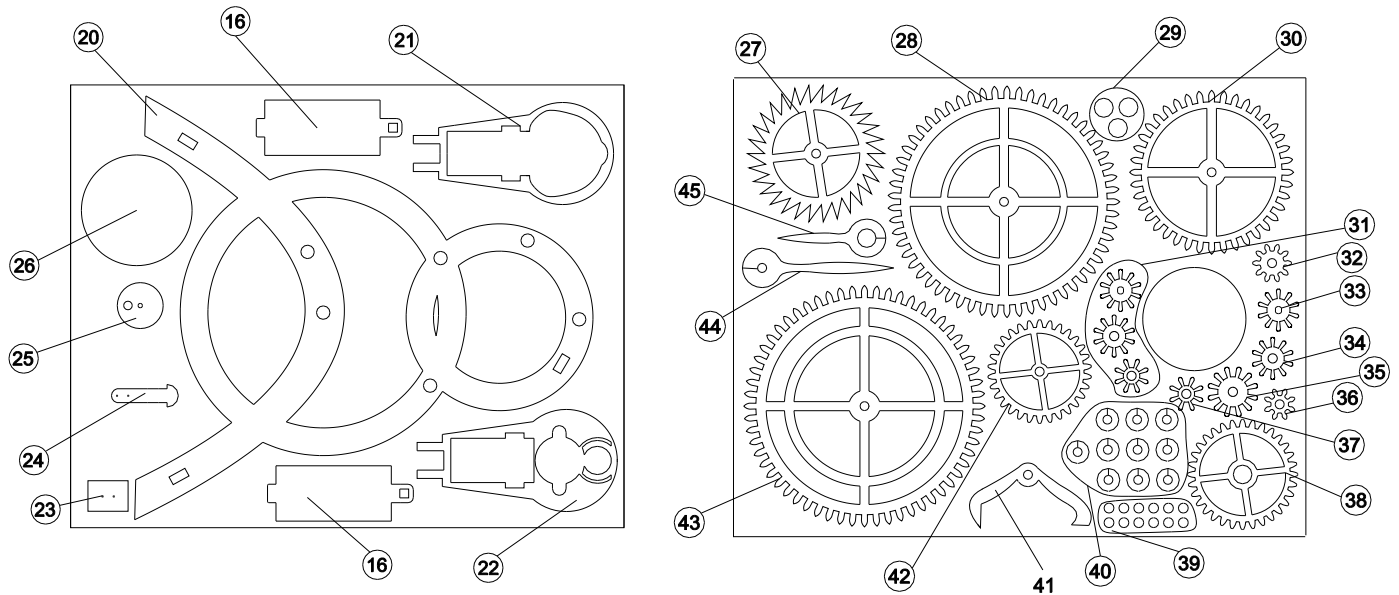

- |                            |                            |                             |
|----------------------------|----------------------------|-----------------------------|
| 20. Front frame back piece | 29. Hour pipe piece [3]    | 38. 32-tooth gear           |
| 21. Weight arm third layer | 30. 40-tooth gear          | 39. 5-minute markers [12]   |
| 22. Weight arm first layer | 31. Spare gears            | 40. Set washers [10]        |
| 23. Wire bending jig       | 32. 10-tooth cannon gear   | 41. Escape lever            |
| 24. Pendulum support       | 33. Drive gear             | 42. 30-tooth gear           |
| 25. Crutch end disk        | 34. 10-tooth gear          | 43. 60-tooth gear           |
| 26. Pendulum bob front     | 35. 12-tooth gear          | 44. Minute hand (gear wood) |
| 27. Escape wheel           | 36. 8-tooth hour hand gear | 45. Hour hand (gear wood)   |
| 28. 57-tooth gear          | 37. 8-tooth gear           |                             |

- 46. Pendulum bob back
- 47. Spacer washers [6]
- 48. Weight arm front
- 49. Weight arm clasp
- 50. Tilt switch adjustment tool
- 51. Small spacer washers [2]

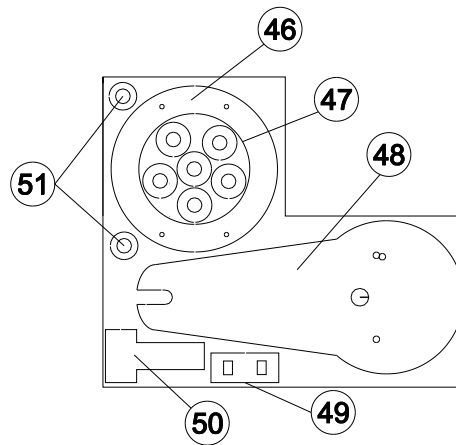

**Hardware**

- 12 nylon shoulder washers
- 2 - 3mm x 12 mm machine screw
- 1 - 3mm x 16 mm machine screw
- 1 - 3mm x 8 mm machine screw
- 4 - 3mm flat washer
- 3 - 3mm hex nut
- 1 - 6-32 x 2 1/2" round head slotted machine screw
- 1 - 6-32 hex nut
- 1 - 1/4" flat nylon washer
- 4 - #2 x 1/4" screws
- 1 - battery holder
- 1 - tilt switch
- 1 - 3" shrink tubing
- 1 - jumper wire (female-female)
- 1 - motor
- 1 - paperclip
- 1 - diode

**1/4" Diameter Dowels**

- 1 - 1"
- 1 - 1 1/2"
- 3 - 3 3/8"
- 1 - 3 7/8"
- 1 - 5 1/4"

# How the Infinity Clock Works

When assembling the clock, it will be beneficial to have some understanding of how the clock works.

The Infinity clock is driven by weight. The weight is an arm that has a drive gear that engages with the main wheel (60-tooth gear) of the clock. As this arm tries to fall downward, it applies a force to the main wheel, causing it to rotate clockwise. This main wheel gear meshes with a train of other gears, causing them to rotate as well. When the weight arm falls a certain amount, a tilt switch inside the arm activates a battery powered motor inside the arm. The motor causes the drive gear to 'walk' the arm back up the main wheel until the switch deactivates the motor. This process of driving and resetting continues until the batteries are depleted.

The speed at which the gear train advances is regulated by a pendulum that swings back and forth. The pendulum is coupled with an escape lever that alternately catches and releases teeth of the escape wheel. This causes the gear train to advance at a controlled, regulated pace.

The faster the pendulum moves back and forth, the faster the escape wheel (and the entire gear train) will be allowed to advance. The pendulum's swing period is determined by the length of the pendulum; the longer the pendulum the slower the clock will run. The pendulum length is adjusted by a rating nut at the bottom of the pendulum. Turning this nut raises or lowers the pendulum bob to increase or decrease the length of the pendulum. Fine tuning the position of this nut allows the clock to be regulated properly to keep time.

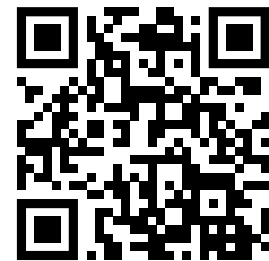
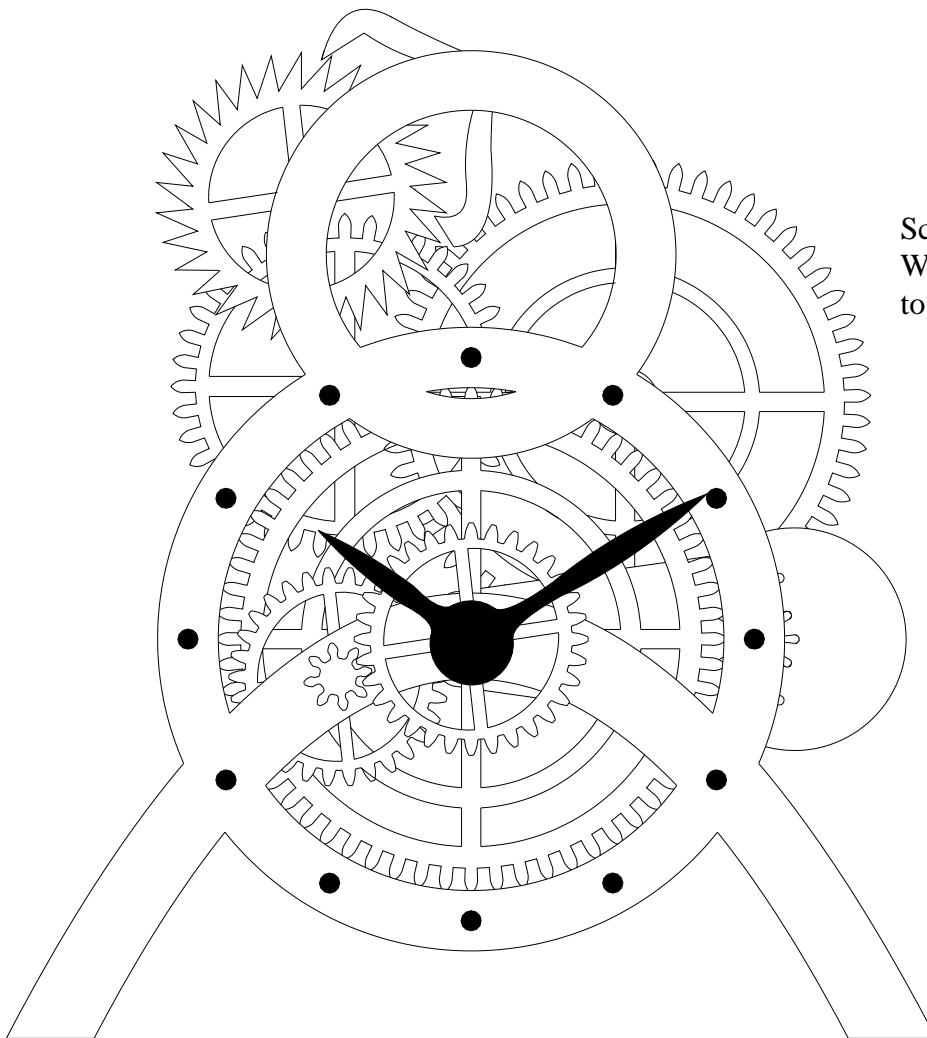

Scan or visit  
[Wooden-Gear-Clocks.com/I10](http://Wooden-Gear-Clocks.com/I10)  
to see a video of the clock

# Frame Assembly

## Parts

- 1 - Front frame front piece (#1)
- 1 - Front frame back piece (#20)
- 12 - 5-minute markers (#39)
- 1 - Rear frame (#10)
- 3 - Pillars (#16)
- 1 - Pillar jig (#4)

## Procedure

1) Glue the front frame front piece onto the front frame back piece. Be sure the two larger holes line up and the pieces are oriented as shown below with the front frame front piece on top.

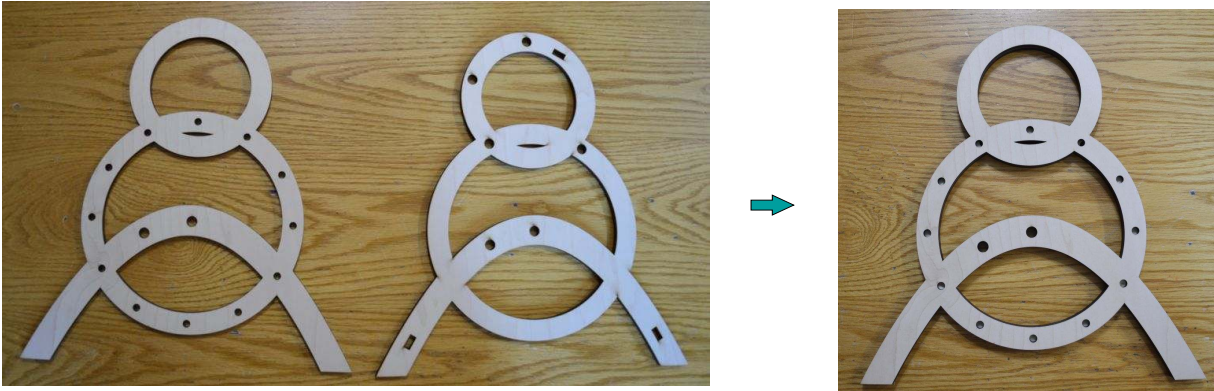

2) Glue the twelve 5-minute markers into the holes in the front frame. Just a tiny amount of glue in the holes is sufficient (apply with a toothpick). Tap the markers in with a hammer. Clean up any glue squeeze out with a damp rag.

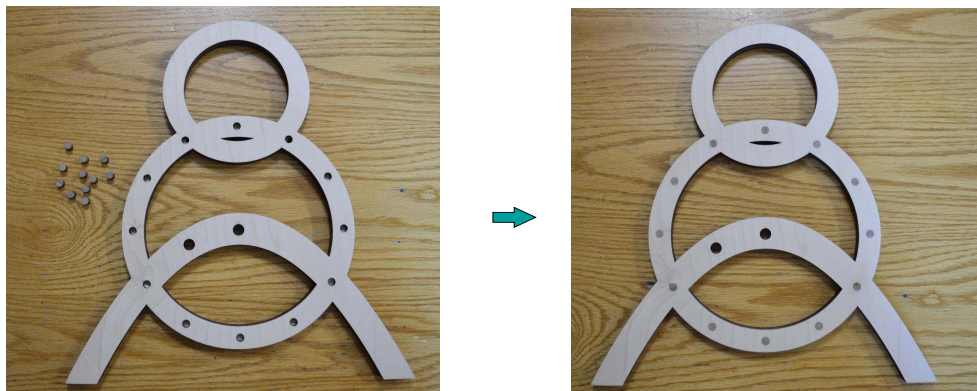

3) Flip over the completed front frame. Glue the three pillars into the holes in the front frame. Use the pillar jig and a hammer (see next page) to tap the pillars down until they are completely seated into the front frame. Clean up any glue squeeze out and immediately go on to the next step.

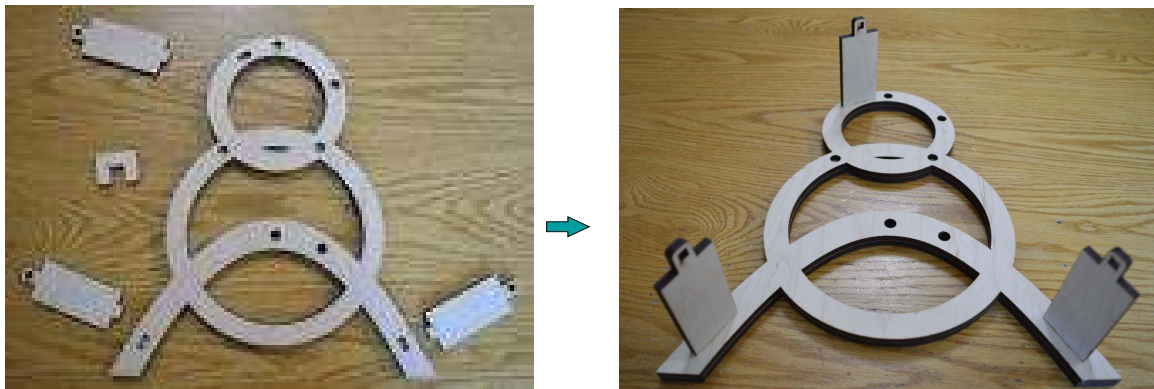

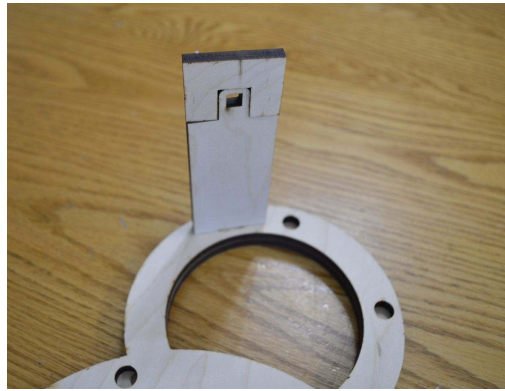

4) Place, but do not glue, the rear frame onto the pillar ends. Leave this assembly alone while the glue dries (about 1 hour). This step ensures that the pillars are all correctly aligned. The tabs should easily slip into the holes. If they are tight, lightly sand the faces of the tabs.

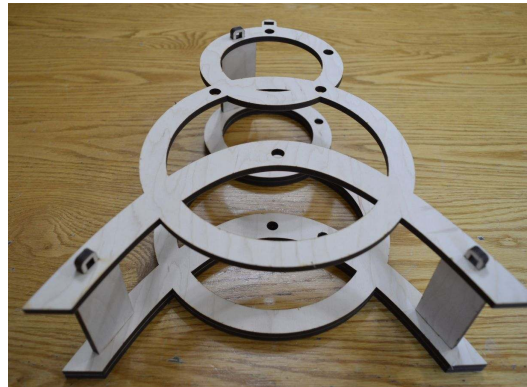

### Parts

- 1 - Rear frame (#10)
- 5 - Nylon shoulder washers

### Procedure

Lay the rear frame on a table **with the holes oriented as shown below**. Place a drop of CA glue on the rim of each of the five  $\frac{3}{8}$ " holes and press a shoulder washer into each hole. It might be necessary to tap the washers in with a hammer. Be sure the washers are completely seated in all five holes.

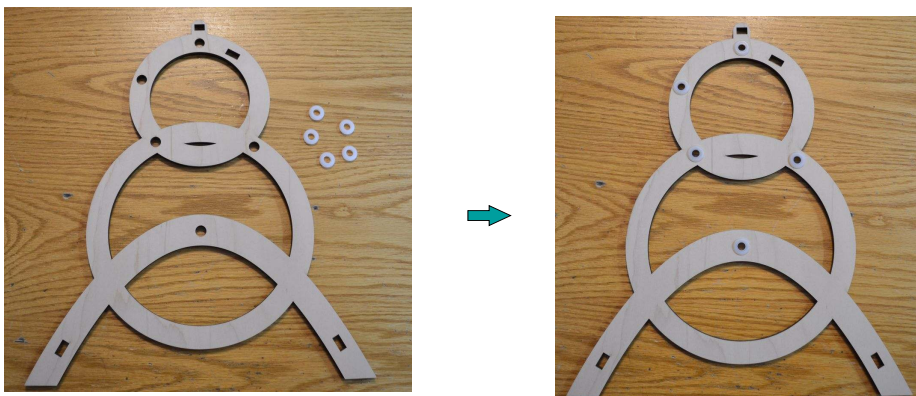

## Parts

- 1 - Front frame (assembled previously)
- 7 - Nylon shoulder washers

## Procedure

1) Lay the front frame on a table with the pillars facing up. Place a drop of CA glue on the rim of each of the six holes and press a shoulder washer into each hole. It might be necessary to tap the washers in with a hammer. Be sure the washers are completely seated in all six holes.

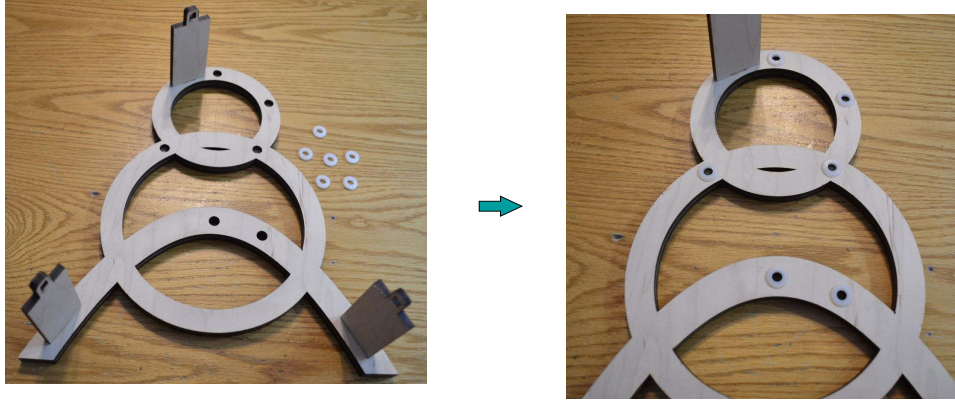

2) Turn the front frame over. As with the other holes, glue a nylon washer into the hole shown below. Note that the center hole does NOT receive a nylon washer. If it needs to be hammered in, support the front frame across the corner of a table top.



## Parts

- 1 - Rear frame (assembled previously)
- 1 - Pendulum support (#24)

## Procedure

Glue the pendulum support into the top of the rear frame. Be sure it is pushed through in the direction indicated in the photo below.



# Pendulum Support Wire

## Parts

- 1- Wire bending jig (#23)
- 1 - Paperclip

## Procedure

Straighten out the paper clip and bend it into a U-shape. Insert the two ends through the holes in the wire bending jig. Push the paper clip in as far as it will go. Then press the jig down on a flat surface to force a U-shape with a flat bottom. Remove the wire from the jig. If you prefer, the paperclip can be bent by the means of your choosing. The goal is a U-shape with a little more the 1/4" gap between its legs (to fit through the jig holes).

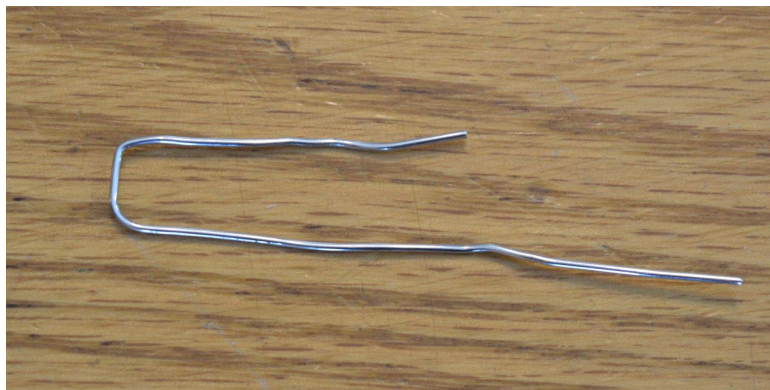
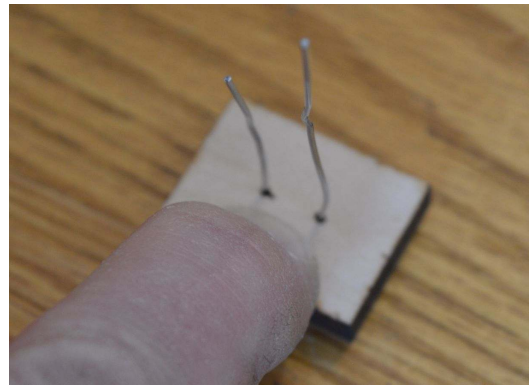

## Parts

- 1- Rear frame (assembled previously)
- 1- Bent paperclip

## Procedure

1) Insert the bent paperclip through the holes in the pendulum support in the direction shown below. Push the wire through (or pull it through with pliers), leaving 1/4" gap at the bottom of the U (you can use a scrap piece of 1/4" kit material as a gauge). **While pushing or pulling the wire through, be careful to support the pendulum support piece so it doesn't break off.**

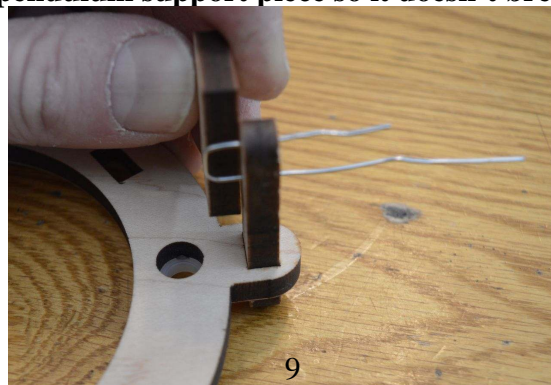

2) While maintaining the 1/4" gap, bend over the two straight pieces of wire against the pendulum support.

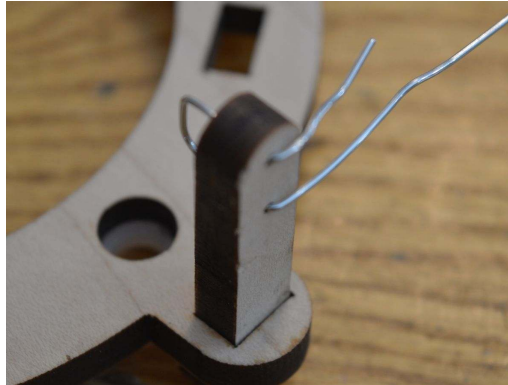

3) Push the wire further into the holes. While wearing safety glasses, use a wire cutter or needlenose pliers to clip off the wires, leaving about 1/8" of bent wire (that is, cut about where the wires met the edge of the pendulum support).



4) Push the wire back through the pendulum support until the small bends catch on the pendulum support.



# Weight Arm End

## Parts

- 1 - Weight arm end middle piece (#18)
- 2 - Weight arm end outer pieces (#19)

## Procedure

Glue the three weight arm end pieces together with the weight arm end middle piece (the one with the tab) in the middle of the two outer pieces. Be sure all edges are aligned. Use a dowel or screwdriver to clear out any glue from the hole. Clean up any glue squeeze out; especially be sure there is no glue in the two slotted regions.

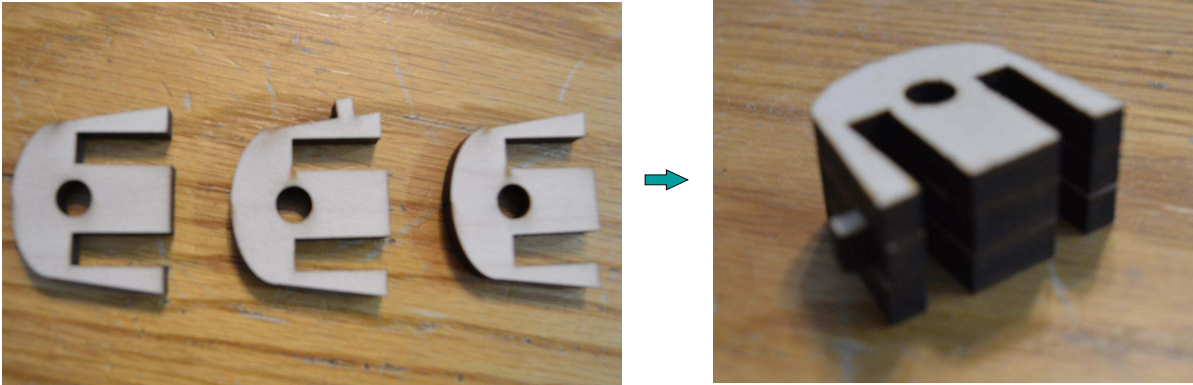

# Tilt Switch Holder

## Parts

- 1 - Tilt switch holder bottom (#13)
- 1 - Tilt switch holder top (#12)

## Procedure

Glue together the two tilt switch holder pieces, making sure the rectangular cutouts are aligned.

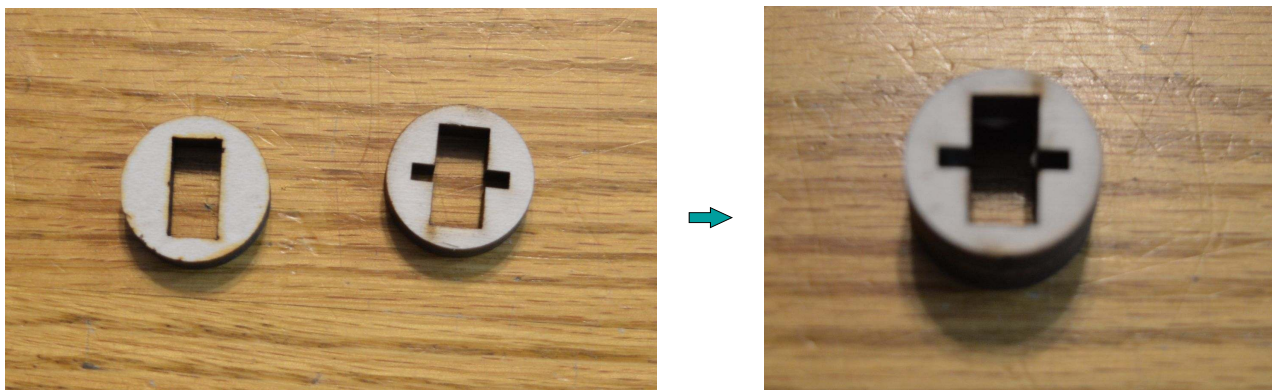

# Weight Arm Veneer (Optional)

## Parts

- 1 - Weight arm front (#48)
- 1 - Weight arm veneer piece (#5)

## Procedure

If you have a cherry or walnut frame and want the weight arm to match the frame (rather than the retaining the light birch color), follow this procedure to adhere a frame-matching veneer to the weight arm front:

- 1) Soak the weight arm veneer piece in pan of water for at least 12 hours (24 hours will make veneer removal easier).
- 2) Use a knife to slip under the veneer and begin peeling it. If it doesn't pull away easily, you may need to soak in water for a longer time.



- 3) Once the veneer is removed, pat it dry with a towel. Place a piece of paper towel above and underneath the veneer and lay a book on top to weight it down. Every few hours, replace the paper towel. Continue until dry.
- 4) If the veneer is wrinkled or curled when dry, use a clothing steam iron to flatten and smooth the veneer.
- 5) Carefully sand (or scrape with a razor blade) the back side to remove the fuzziness.
- 6) Glue the veneer to the weight arm front, applying clamping pressure over the entire surface while the glue dries.

# Weight Arm

## Parts

- 1 - Weight arm front (#48)
- 1 - Motor
- 2 - 3 mm x 12 mm machine screws
- 2 - 3 mm washers
- 2 - 3 mm hex nuts

## Procedure

Insert the motor into the weight arm front with the shaft protruding through the veneered (or better) face of the wood and the motor housing holes lined up with the holes in the weight arm front. Insert the two machine screws through the weight arm front. On the motor side, secure the motor with washers and nuts, tighten snugly.

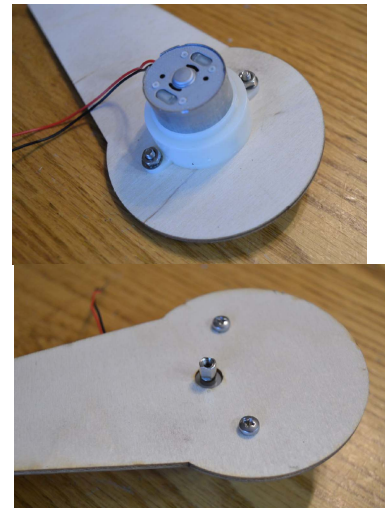
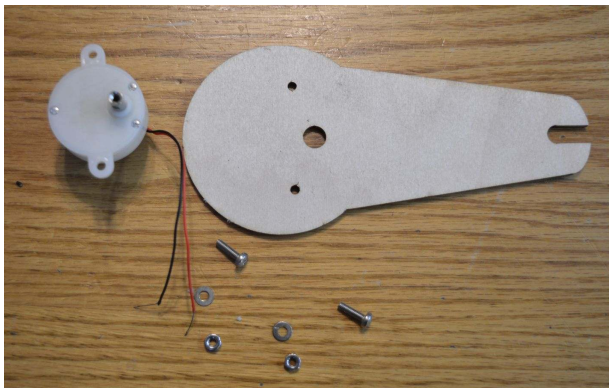

## Parts

- 1 - Weight arm front (previously assembled)
- 1 - Weight arm first layer (#22)

## Procedure

Glue the weight arm first layer to the motor side of the weight arm front, passing the motor wires through the motor hole cut out. **Do not glue the C-shaped section next to the motor.** Be sure all edges are aligned and any glue squeeze out is cleaned up.

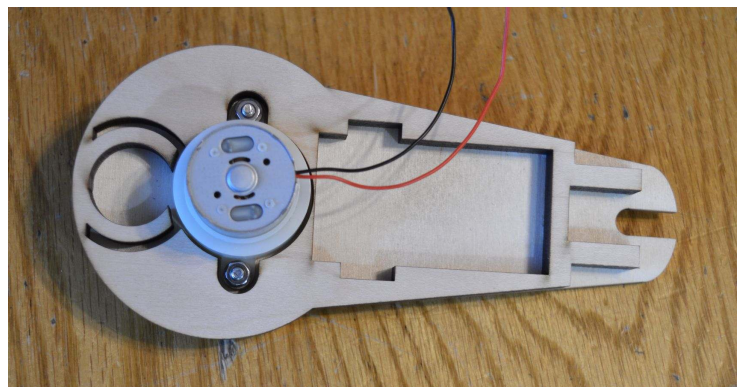

## Parts

- 1 - Weight arm (previously assembled)
- 1 - Tilt switch holder (previously assembled)

## Procedure

Insert the tilt switch holder into the weight arm. Do not glue it. Be sure the tilt switch holder is all the way down. Twist the tilt switch holder until the rectangular cut out is oriented as shown below (the rectangle is slightly off from being perpendicular to the long axis of the weight arm).

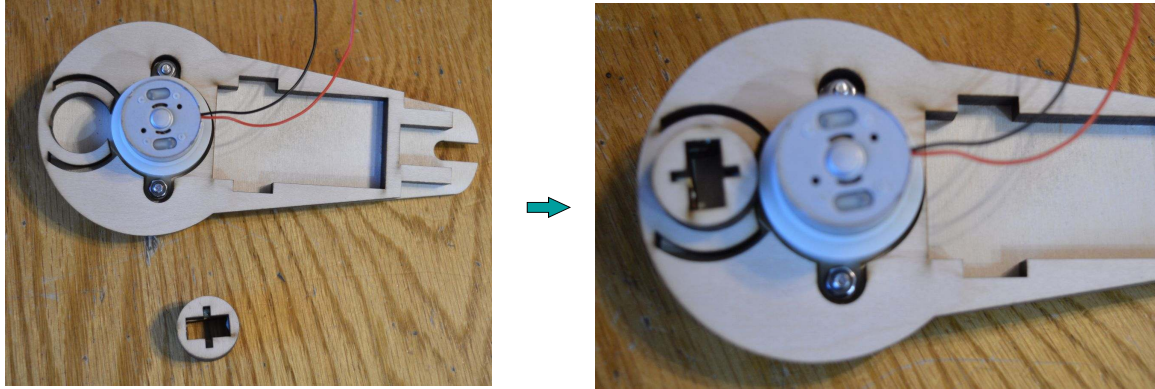

## Parts

- 1 - Weight arm (previously assembled)
- 1 - Weight arm second layer (#15)
- 1 - Weight arm end (previously assembled)

## Procedure

Glue the weight arm second layer to the motor side of the weight arm. **Be sure the small tab is on the side shown below.** Also, do not allow glue to contact the tilt switch holder since it needs to be free to adjust. Be sure all edges are aligned and any glue squeeze out is cleaned up. Test fit the weight arm end into the end of the weight arm to verify that it fits in cleanly then remove it.

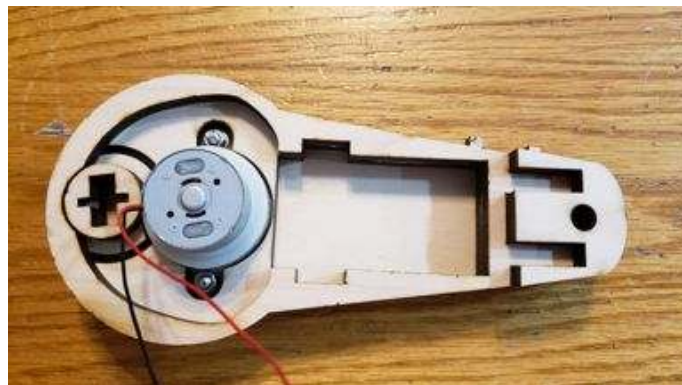
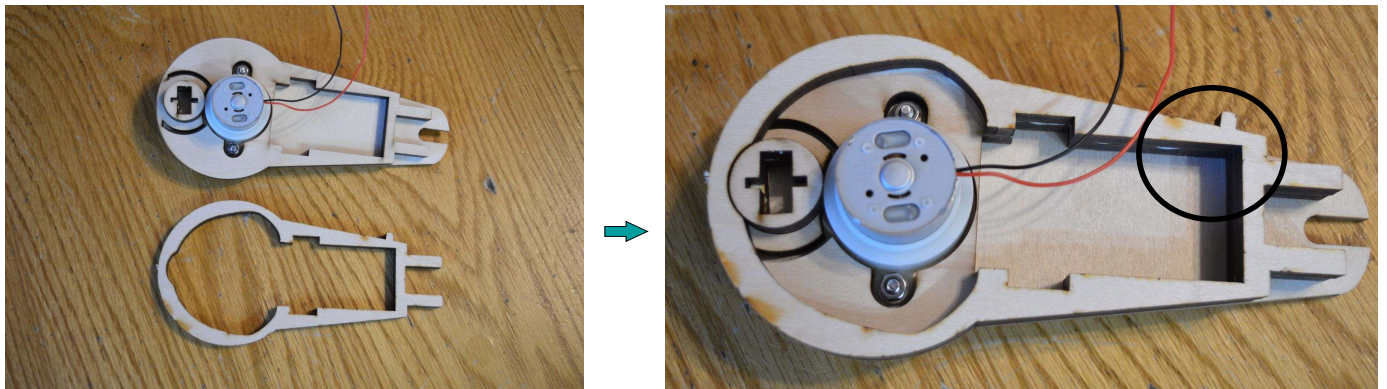

## Parts

- 1 - Weight arm (previously assembled)
- 1 - Weight arm third layer (#21)
- 1 - Weight arm end (previously assembled)

## Procedure

Glue the weight arm third layer to the motor side of the weight arm. Do not allow glue to contact the tilt switch holder since it needs to be free to adjust. Be sure all edges are aligned and any glue squeeze out is cleaned up. Test fit the weight arm end to be sure it fits then remove it.

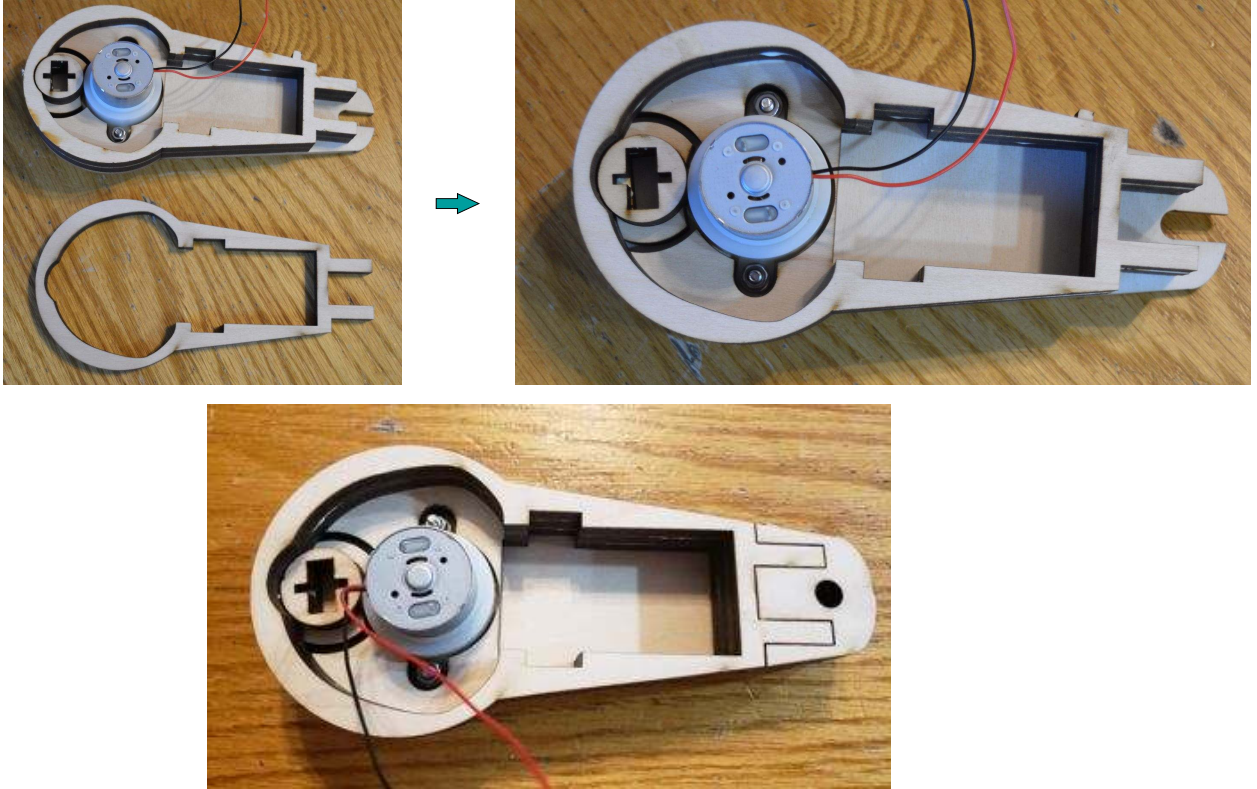

## Parts

- 1 - Weight arm (previously assembled)
- 1 - Weight arm back (#14)
- 1 - Weight arm end (previously assembled)

## Procedure

Glue weight arm back to the motor side of the weight arm. Do not allow glue to contact the tilt switch holder since it needs to be free to adjust. Be sure all edges are aligned and any glue squeeze out is cleaned up. Test fit the weight arm end into the weight arm to verify it fits then remove it. The weight arm end needs to be removable. If it is too tight, do some light sanding to improve the fit.

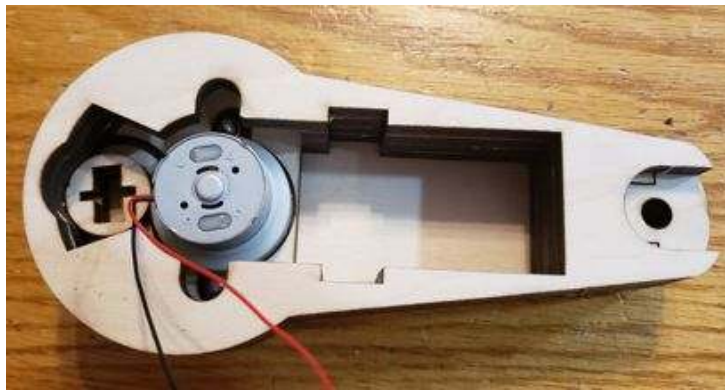
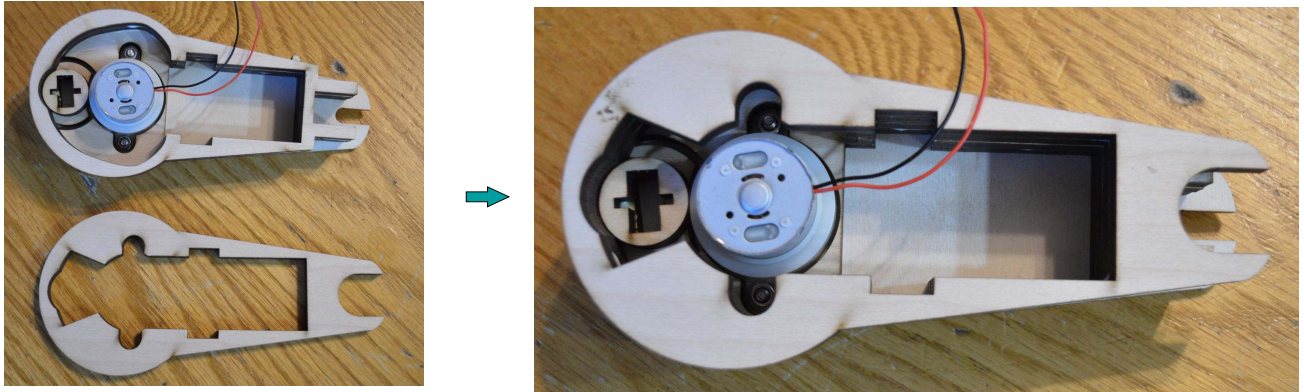

## Parts

- 1 - Weight arm (previously assembled)
- 1 - Drive gear (#33)
- 1 - 3 mm x 8 mm machine screw
- 1 - 3 mm washer

## Procedure

Fit the drive gear onto the motor shaft. Place a 3 mm washer on the machine screw. Add a tiny amount of CA glue or threadlocker to the threads of the machine screw. Secure it into the motor shaft until tight.

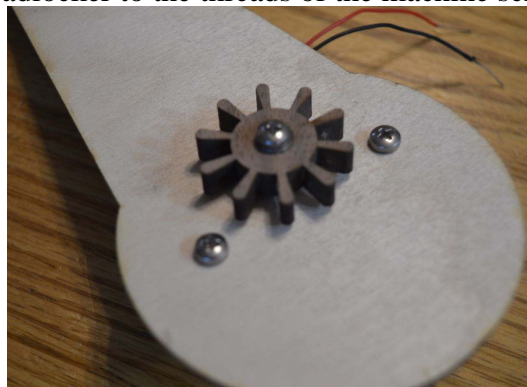

## Parts

- 1 - Battery holder
- 4 - AA batteries
- 1 - Weight arm (previously assembled)

## Procedure

- 1) Install four AA batteries in the battery holder. Be sure the ends of the battery are oriented correctly (flat ends contact the springs in the holder).
- 2) Remove approximately 3/4" of insulation from the ends of the motor and battery holder wires. This can be done with a small wire strippers, but an easier way is to use a lighter to burn that section of insulation and then peel off the residue (this will be demonstrated in the video instructions on page 18).

## Parts

- 1 - Weight arm (previously assembled)
- 1 - Battery holder with batteries installed
- 1 - Jumper wire
- 1 - Shrink tubing
- 1 - Tilt Switch
- 1 - Diode

## Procedure

The drive gear must turn counterclockwise when the motor is on. The following procedure is used to determine which way the wires must be connected to achieve this.

- 1) Twist together or touch the red battery holder wire to the red motor wire and the black wire to the black wire. Note the direction that the drive gear turns then disconnect the wires. If the drive gear turns counterclockwise, the motor's polarity matches the battery; in the next steps the wires will be connected in this way (red to red, black to black). If the drive gear turns clockwise, in the next step the wires will need to be reversed (red to black, black to red). **Remove one battery from the battery holder.**

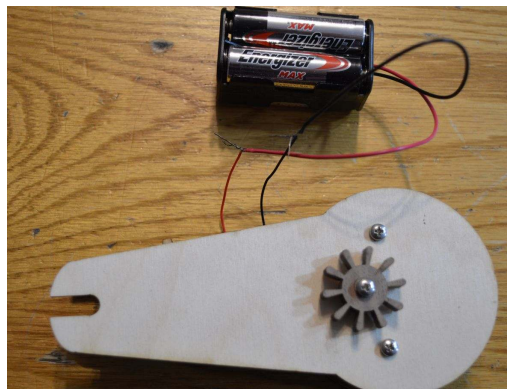

2) Cut the jumper wire in half. Remove the insulation from the last 3/4" of insulation from the both pieces. Slide the jumper wire connectors onto the two pins of the tilt switch show below (with the tilt switch pins facing upward, it is the two left pins).

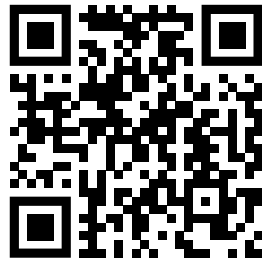

Scan or visit [Wooden-Gear-Clocks.com/i11](http://Wooden-Gear-Clocks.com/i11)  
to watch a video of the following steps 3-9

3) If the motor polarity test resulted in “red to red” connections, twist the red motor wire and one of the tilt switch jumper wires together. (If the motor polarity test resulted in “red to black” connections, instead connect the black motor wire to a jumper wire following the same procedure.)



4) Notice that the diode has a stripe on one end. Twist the wire motor/jumper wire combination from the previous step onto the diode lead that is next to the striped end of the diode. **IT IS VITAL THAT THE DIODE LEAD NEAREST THE STRIPE IS ONE THAT GETS CONNECTED.**

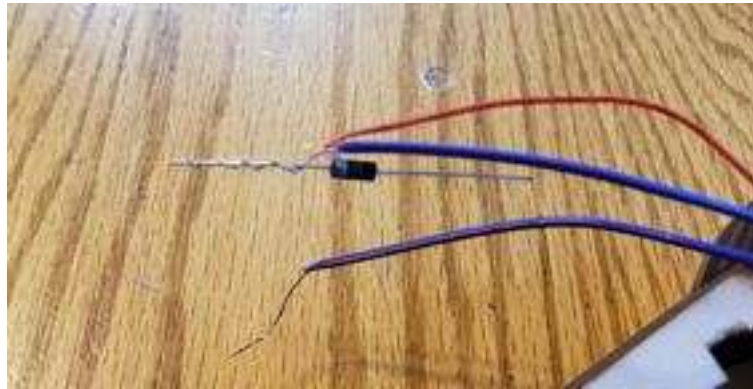

5) Cut two pieces of shrink tubing to be slightly longer than the diode lead (7/8"). Carefully slip a piece of shrink tubing onto this connection with the tubing covering the entire lead (it may help to twist the shrink tubing in the same direction as the wire twist while sliding the tubing on). Use a heat gun or lighter to gently heat the shrink tubing to shrink it over the connection. After a couple of minutes, tug on the wires to be sure the connection is secure.

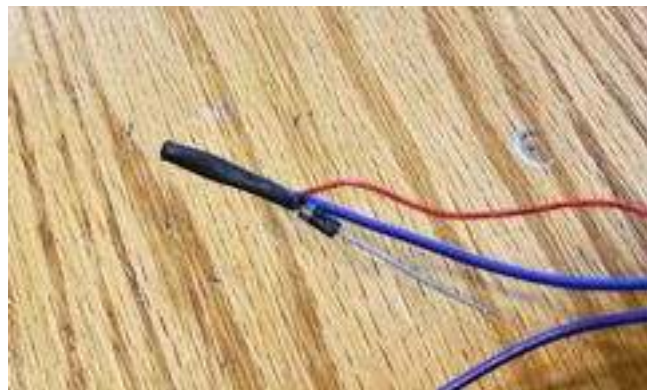

6) Twist the remaining motor wire together with the black wire from the battery box. Then twist this connection tightly onto the remaining diode lead and apply a 7/8" piece of shrink tubing as was done with the other diode lead.

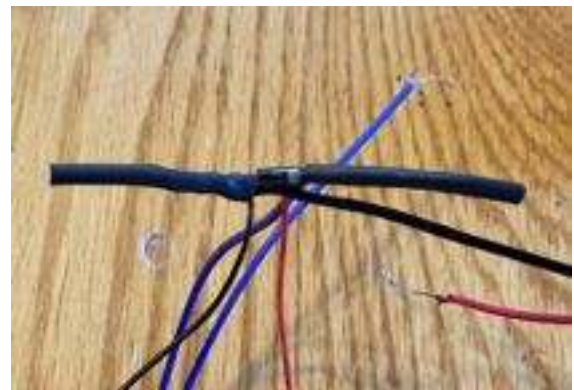
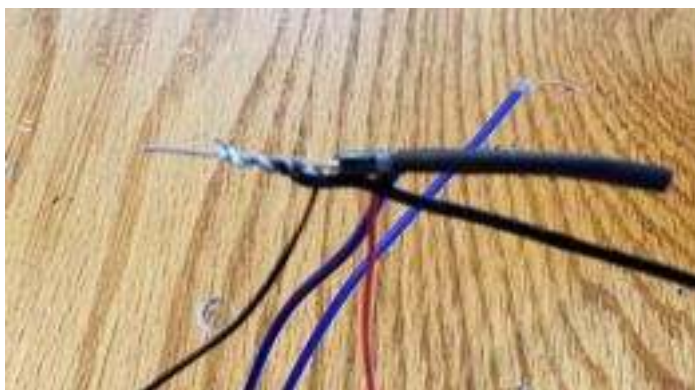

7) Slip the remaining piece of shrink tubing onto the red wire from the battery box.

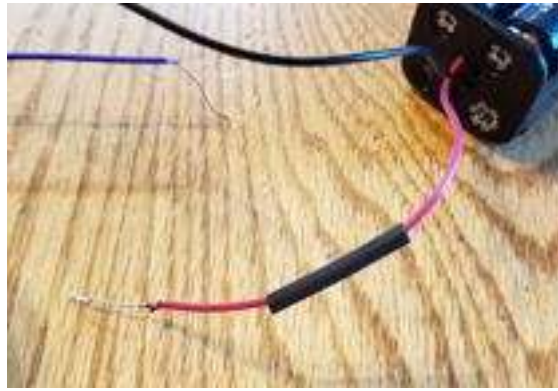

8) Twist the red wire from the battery box together with the remaining tilt switch jumper wire. Next, fold the connection over, slip the shrink tubing over the connection and heat to shrink the tubing.

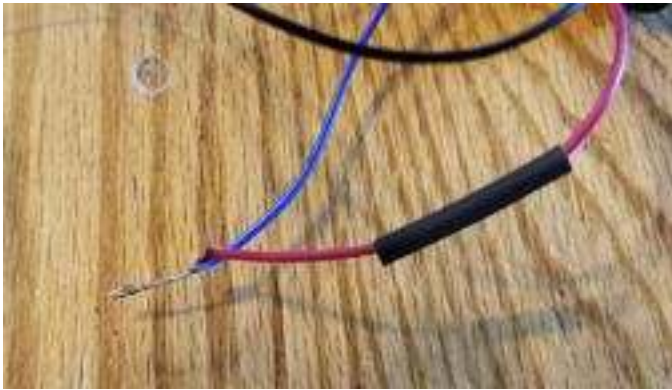

9) At this point, all connections have been made.

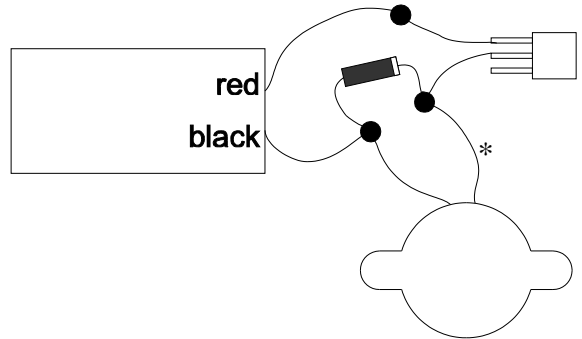
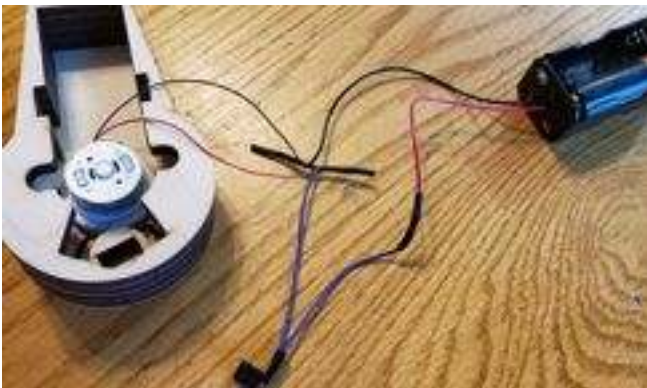

\*the wire that, when connected to the red battery box wire, caused the motor to turn counterclockwise.

**The tilt switch leads are very fragile. Be sure not to bend or place any stress on them during the next process.**

10) Carefully press the tilt switch into the tilt switch holder with the leads oriented as shown below (leads are on the bottom of the slot and facing up). Use the eraser end of a pencil to push the tilt switch down until it bottoms out in the holder. You might have to hold the jumper wires in place so they don't pull off during installation of the tilt switch.



11) The face of the battery holder with the missing battery will be facing up when installed into the weight arm. Hold the weight arm in your hands and press the battery holder into cavity in the weight arm until it bottoms out. The fit should be snug enough to keep the battery box in place, but not so tight that the battery box can't be pried out. Without touching or pulling on the tilt switch connections, carefully tuck the loose wires under the lip of the weight arm back.



12) At this point, you can test the weight arm. Insert the fourth battery. Hold the weight arm horizontally so that you are looking at the drive gear and the drive gear is on the right hand side. If you tip the right side of the arm down, the motor should start to turn counterclockwise. If you tip the right side of the arm up, the motor should stop. If this does not happen, recheck your battery installation and electrical connections.

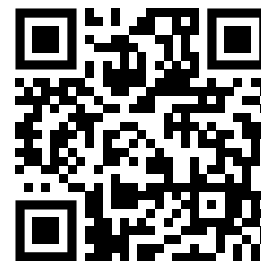

Scan or visit [Wooden-Gear-Clocks.com/i1](http://Wooden-Gear-Clocks.com/i1) to watch a video of step 12

13) Remove one battery and set the weight arm off to the side.

# Marking Gear Locations

The following pages contain diagrams to locate the parts on the arbors (dowels). These diagrams are to scale. Lay each dowel on the corresponding diagram and make pencil marks on the dowels to indicate the gear locations.

# Mounting Gears on Arbors

The process for mounting the gears on the arbors is demonstrated in the next set of instructions for the 60-tooth gear. The same process will be used for the rest of the gears. This involves setting the gear on a flat, sturdy surface and using a hammer to drive the dowel into the gear. Then the gear is placed on top of the staking jig and the dowel is driven through further. Next, the gear is placed on a pair of blocks and the dowel is driven to the marked location on the dowel (glue is applied before the gear is put to its final location). Finally, for the larger gears, the squaring jig is used to verify that the gear is perpendicular to the dowel and any adjustments are made.

# Arbor Preparation

After the gears are mounted on the arbors, some sanding (more like polishing) and lubrication needs to be done. The gear location diagrams show regions of the arbors that will ride in the nylon bearings. These regions need to be polished smooth and lubricated. Take a narrow strip of 220 grit sandpaper and lightly polish the indicated regions of the dowels. Repeat with 400 or 600 grit sandpaper. Then coat these areas with a layer of pencil lead (simply take a pencil and color these regions of the dowel).

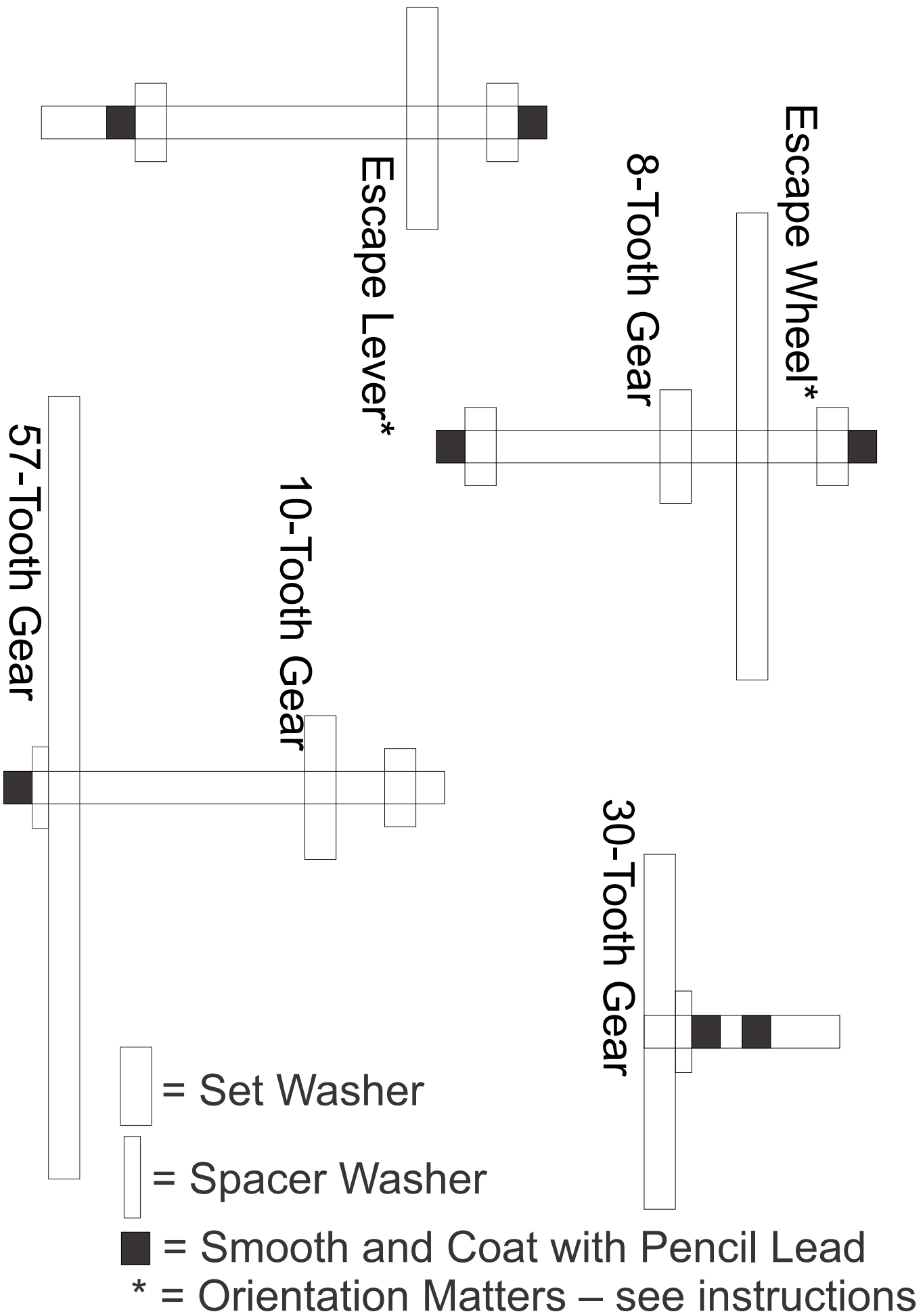

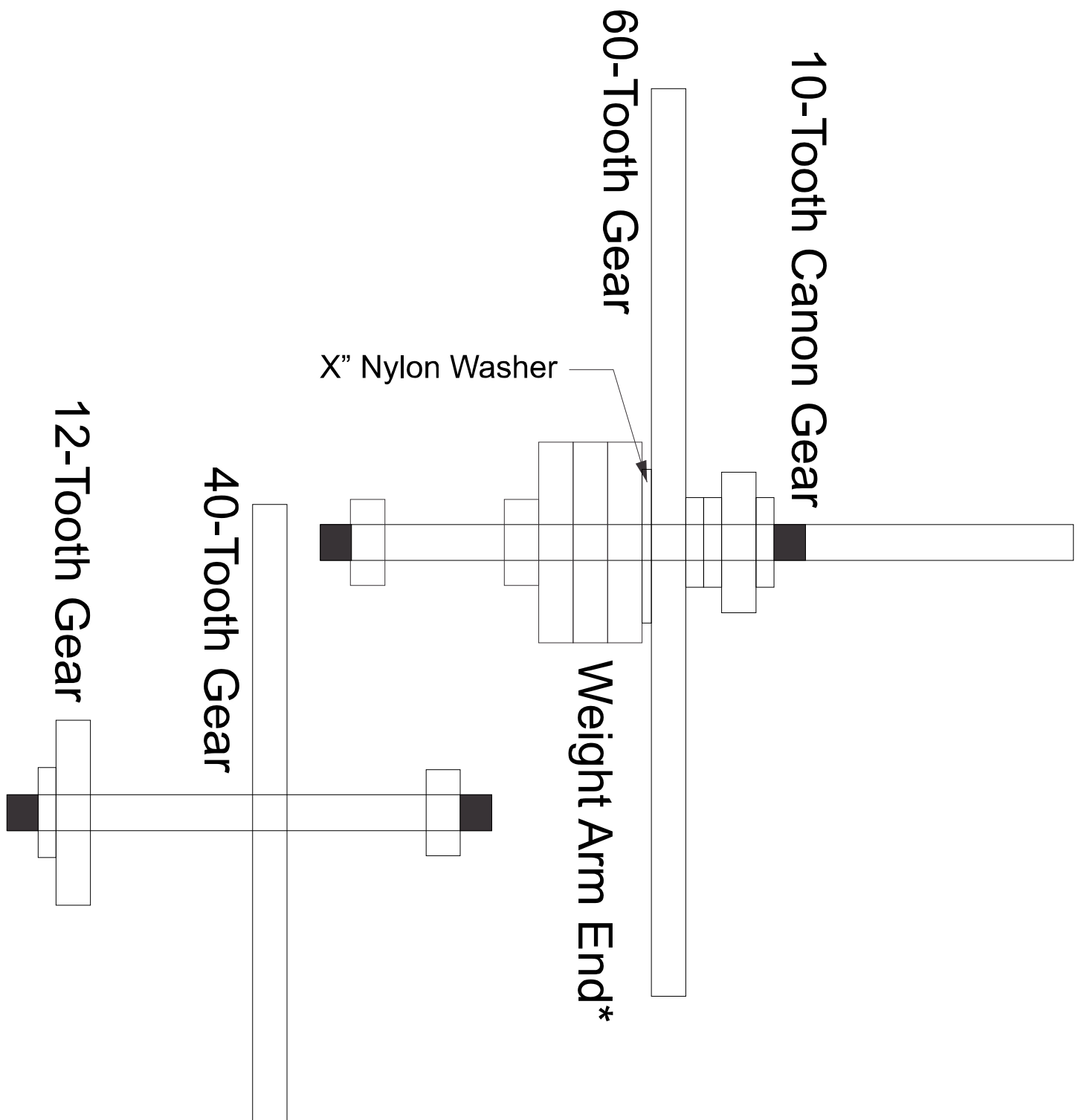

= Set Washer



= Spacer Washer



= Smooth and Coat with Pencil Lead

\* = Orientation Matters – see instructions

# 60-Tooth Gear Unit

## Parts

- 1 - Weight arm end (previously assembled)
- 1 - Weight arm (previously assembled)
- 1 - 60-tooth gear (#43)
- 1 - 5 1/4" dowel
- 1 - Gear staking jig (#8)
- 1 - Squaring jig (#3)
- 1 - 10-tooth cannon gear (#32)
- 3 - Spacer washers (#47)
- 2 - Set washer (#40)

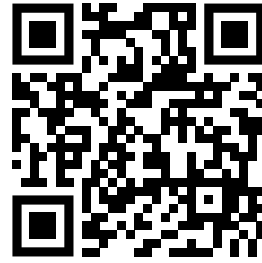

Scan or visit [Wooden-Gear-Clocks.com/i5](http://Wooden-Gear-Clocks.com/i5) to watch a video of this process

## Procedure

1) Lay the 60-tooth gear on a flat, sturdy surface. Use a hammer to carefully tap the 5 1/4" dowel into the hole in the gear until the dowel bottoms out through the gear.

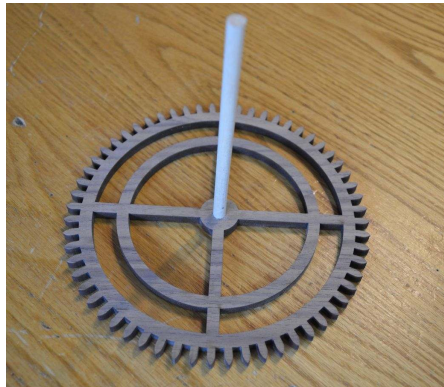

2) Place the gear unit on top of the gear staking jig, with the hole centered beneath the dowel. Use a hammer to tap the dowel until the gear bottoms out through the gear staking jig.

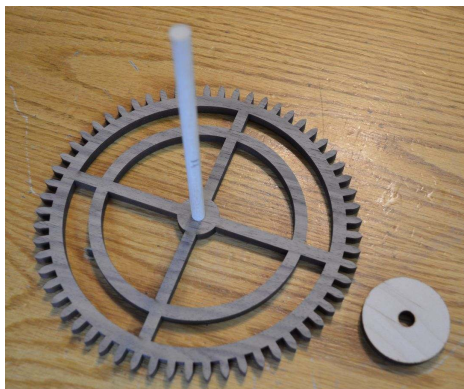

3) Place the gear unit (with staking jig) on top of pair of blocks separated by 1/4-1/2". Use a hammer to tap the dowel through until the gear is about 1/2" from reaching the gear location mark on the dowel. Spread a small amount of glue around the dowel where the gear will be located. Then drive the dowel through until the gear reaches the gear location mark. Wipe away any excess glue and immediately proceed to the next step.



4) Use the squaring jig to verify that the gear is perpendicular to the dowel. If needed, push the dowel to adjust it. Check in both directions. Set aside and allow the glue to dry. (TIP: another way to test gear trueness is to hold the dowel ends in your fingertips and spin the gear; viewing the gear from the side lets you see if there is excessive wobble in the gear.)

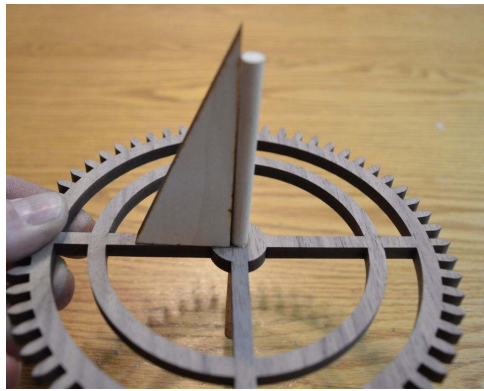

Note: this same procedure will be followed for the rest of the gear units.

5) Push two spacer washers onto the longer half of the dowel. Install the 10-tooth cannon gear up tight to the spacer washers.

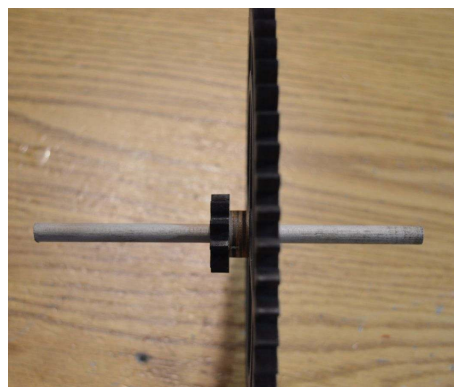

6) Place the flat nylon washer onto the other half of the dowel.

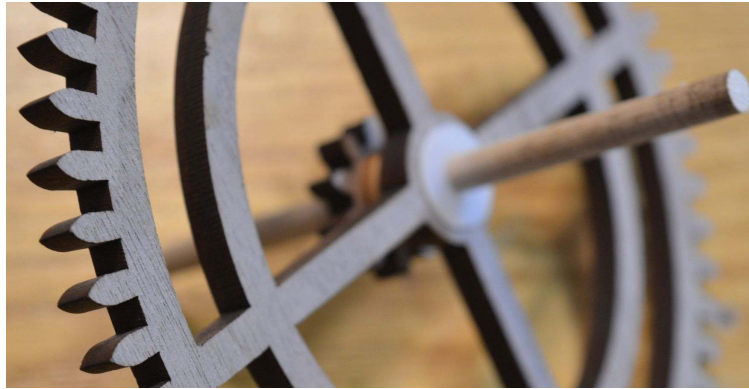

7) Slip the weight arm end into the weight arm. Be sure the tab on the weight arm is next to the tab on the weight arm end.



8) Slide the weight arm onto the dowel with the drive gear meshing with the 60-tooth gear. Twist a set washer onto the dowel so that it is next to the weight arm end. The set washers should be able to be twisted onto the dowels, but if they are too tight, you can use the same procedure that was used to mount the gears on the arbors. The set washer should be friction fit. If it loosens in the future, it can be glued at that time.



9) Remove the weight arm from the weight arm end. Verify that the weight arm can be easily be inserted and removed from the weight arm end. Move the set washer slightly if needed. Leave the weight arm apart from the weight end for now.

10) Twist a set washer onto the end of the dowel to the marked location on the dowel. This should remain unglued for now. After the location has been fine tuned in the clock, it can then be glued.

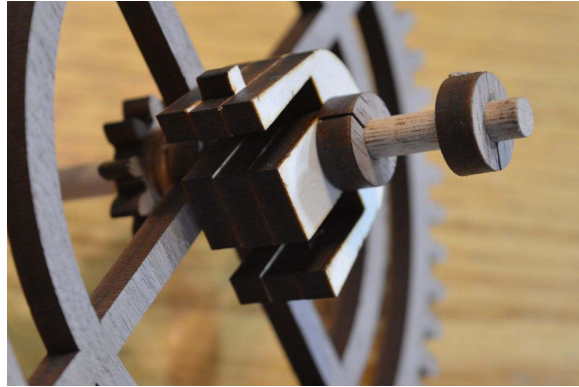

11) Place a spacer washer next to the 10-tooth cannon gear.



## 40-Tooth Gear Unit

### Parts

- 1 - 40-tooth gear (#30)
- 1 - 12-tooth gear (#35)
- 1 - Set washers (#40)
- 1 - Spacer washer (#47)
- 1 - 3 3/8" dowel
- 1 - Gear staking jig (#8)

### Procedure

Using the gear installation process described earlier, install the 40-tooth gear on the 3 3/8" dowel. Then install the 12-tooth gear on the dowel. Twist a set washer onto the marked location on the dowel and slide on the spacer washer.



# Escape Lever Unit

## Parts

- 1 - Escape lever (#41)
- 2 - Set washers (#40)
- 1 - 3 7/8" dowel

## Procedure

1) The two flat faces of the escape lever need to be polished smooth and lubricated. Place a piece of 220 grit sandpaper on the edge of a flat tabletop. Carefully sand the two flat faces of the lever by rubbing along the sandpaper. Be careful to keep the faces flat on the surface so you don't alter the shape of the faces. Repeat this process with 400 grit sandpaper. Finally, coat the two flat surfaces with graphite by coloring them with pencil lead.

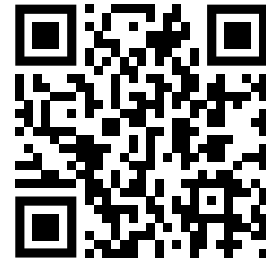

Scan or visit [Wooden-Gear-Clocks.com/i2](http://Wooden-Gear-Clocks.com/i2) to watch a video of step 1

2) Using the gear installation process described earlier, install the escape lever on the 3 7/8" dowel. **Be sure the escape lever is oriented as shown below.** In the photo, the longer part of the dowel is protruding upwards.



3) Twist the two set washers onto the dowel at the marked locations. They should be friction fit and can be glued once the clock is assembled and the exact location verified.



# Escape Wheel Unit

## Parts

- 1 - Escape wheel (#27)
- 1 - 8-tooth gear (#37)
- 2 - Set washers (#40)
- 1 - 3 3/8" dowel
- 1 - Gear staking jig (#8)

## Procedure

- 1) Using the gear installation process described earlier, install the escape wheel on the 3 3/8" dowel. **Be sure the escape wheel teeth are oriented as shown below.** Next, mount the 8-tooth gear on the arbor.



- 2) Twist the two set washers onto the dowel at the marked locations. They should be friction fit and can be glued once the clock is assembled and the exact location verified.



# 57-Tooth Gear Unit

## Parts

- 1 - 57-tooth gear (#28)
- 1 - 10-tooth gear (#34)
- 1 - Set washer (#40)
- 1 - Spacer washer (#47)
- 1 - 3 3/8" dowel
- 1 - Gear staking jig (#8)

## Procedure

Using the gear installation process described earlier, install the 57-tooth gear on the 3 3/8" dowel. Then install the 10-tooth gear and set washer. Finally, place a spacer washer onto the dowel next to the 57-tooth gear.



# 30-Tooth Gear Unit

## Parts

- 1 - 30-tooth gear (#42)
- 1 - Spacer washer (#47)
- 1 - 1 1/2" dowel

## Procedure

Drive the 1 1/2" dowel into the 30-tooth gear until the dowel bottoms out on the tabletop. Add a spacer washer onto the dowel.



**If you have not yet done so, do the arbor lubrication process described on page 21.**

# Hour Gear

## Parts

- 3 - Hour pipe pieces (#29)
- 1 - 32-tooth gear (#38)

## Procedure

Glue the three hour pipe pieces together. Make sure the outer edges are all aligned. Use a piece of dowel to clear out any glue from the inside of the pipe. Clamp while the glue dries.

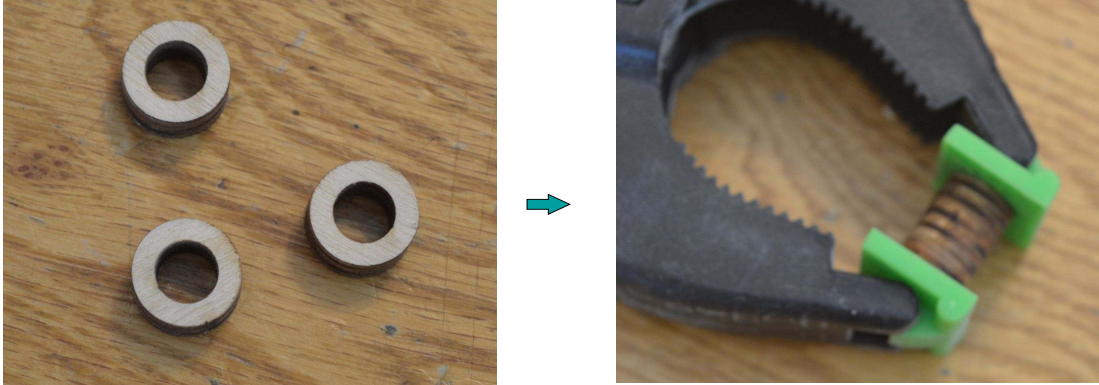

Apply some glue to the inside of the hole in the 32-tooth gear. Carefully tap the hour pipe into the 32-tooth gear until it bottoms out in the hole.

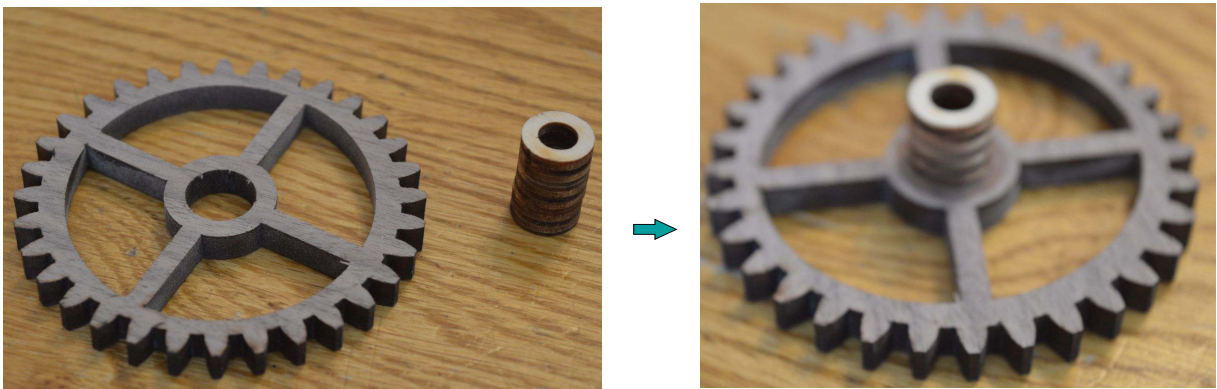

## Parts

- 1 - Hour gear (assembled previously)
- 1 - Hour hand (#6 or #45)

## Procedure

There are two sets of hands included. Choose the one that matches the frame wood or the one that matches the gear wood. Twist the hour hand onto the hour pipe. The fit should be a “friction fit” which is tight enough for the hand to maintain its position, but loose enough that the hand can be repositioned on the hour pipe. If it is too tight, sand the hour pipe slightly. If it is too loose, apply a thin layer of glue to the hour pipe and allow to dry before fitting the hour hand on.

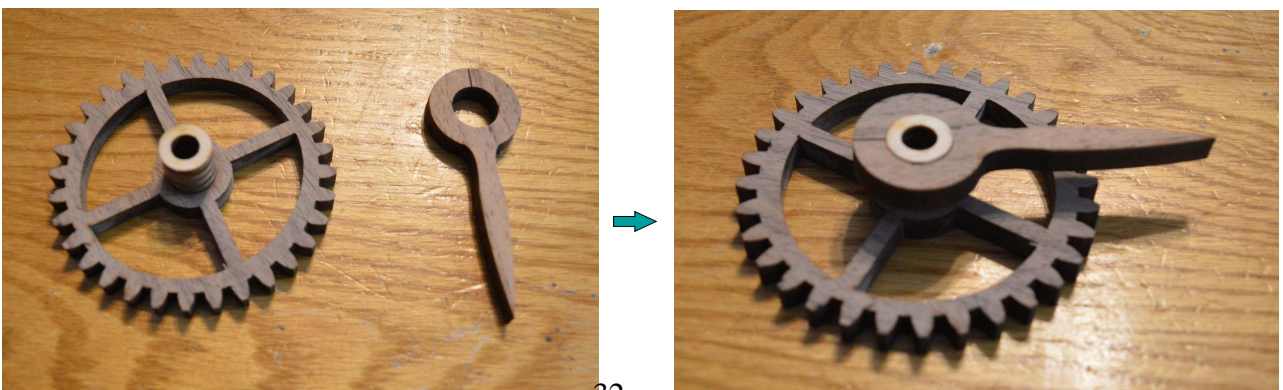

# Crutch

## Parts

- 1 - Crutch arm (#11)
- 1 - Crutch end disk (#25)
- 1 - 1" dowel
- 1 - 3 mm x 16 mm machine screw
- 1 - 3 mm washer
- 1 - 3 mm hex nut

## Procedure

1) Glue the 1" dowel into the hole in the crutch end disk. Tap in with a hammer so the dowel bottoms out completely.



2) Push the machine screw through the crutch end disk and into the smaller hole in the end of the crutch arm. Secure with a washer and nut. Align the crutch end disk so the dowel is in line with the long axis of the crutch as shown below. Tighten the machine screw so the crutch end disk doesn't move but is able to be repositioned (this will be an adjustment that will need to be made later).

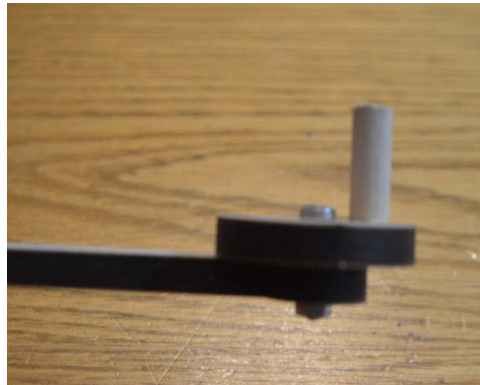

# Pendulum

## Parts

- 1 - Pendulum shaft (#2)
- 1 - 6-32 x 2 1/2" machine screw

## Procedure

Press the machine screw into the end of the pendulum shaft. The slot in the screw head fits into the small tab in the cutout.

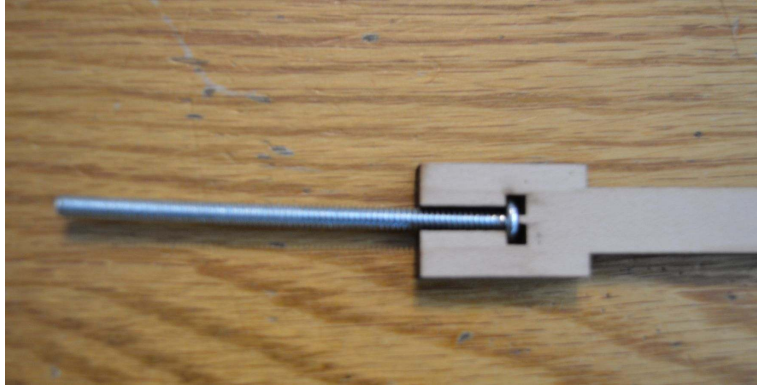

## Parts

- 2 - Pendulum bob middle (#17)
- 4 - #2 x 1/4" screws
- 1 - Pendulum shaft (previously assembled)
- 1 - Pendulum bob back (#46)

## Procedure

1) Sandwich the pendulum shaft between the two pendulum bob middle pieces. Note that ends of these pieces are different; the wider gap is around the shaft and the narrower gap is around the machine screw. Place the pendulum bob back on top of the pendulum bob middle pieces and secure with the four #2 x 1/4" screws through the predrilled holes. .

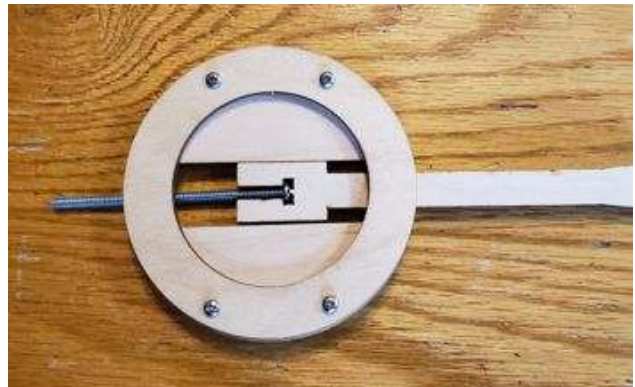
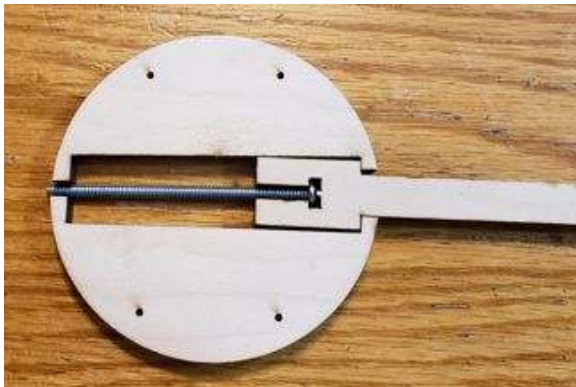

2) Flip the pendulum bob over. Verify that the pendulum shaft is free to slide within the channel. If necessary, sand the edges of the pendulum shaft.

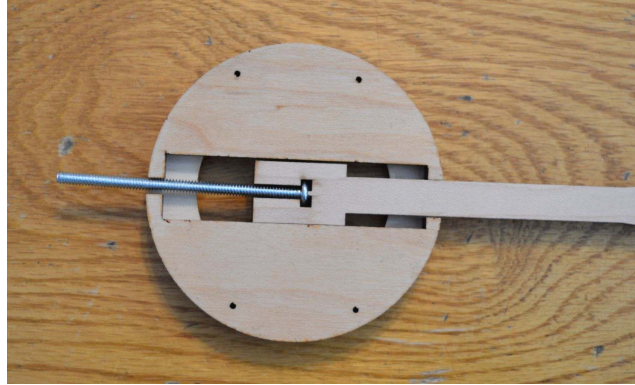

### Parts

- 1 - Pendulum (assembled previously)
- 1 - Pendulum bob front (#26)

### Procedure

Glue the pendulum bob front to the pendulum bob middle pieces. Be sure no glue gets in the channels since the shaft needs to slide freely within the channel.

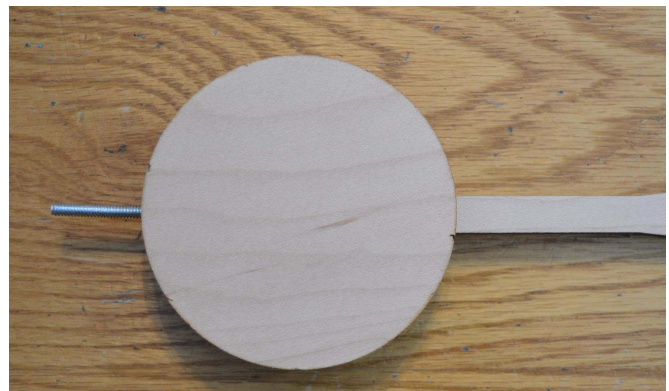
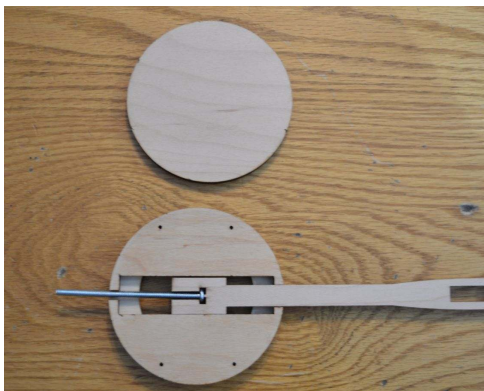

### Parts

- 1 - Pendulum (assembled previously)
- 1 - 6-32 hex nut

### Procedure

With about 3/4" of screw protruding from the pendulum bob, turn the nut onto the pendulum screw until it contacts the pendulum bob.



# Final Assembly

## Parts

- 1 - Front frame (assembled previously)
- 1 - Rear frame (assembled previously)
- 3 - Wedges (#9)
- 2 - Wood blocks
- 1 - 30-tooth gear unit (assembled previously)
- 1 - 60-tooth gear unit (assembled previously)
- 1 - 57-tooth gear unit (assembled previously)
- 1 - 40-tooth gear unit (assembled previously)
- 1 - Escape lever unit (assembled previously)
- 1 - Escape wheel unit (assembled previously)
- 1 - 8-tooth hour hand gear (#36)
- 1 - 32-tooth gear with hour hand (assembled previously)
- 1 - Minute hand (#7 or #44)
- 1 - Crutch (assembled previously)
- 2 - Small spacer washers (#51)
- 2 - Set washers (#40)

## Procedure

- 1) Place the front frame on the wood blocks with the pillars facing up.

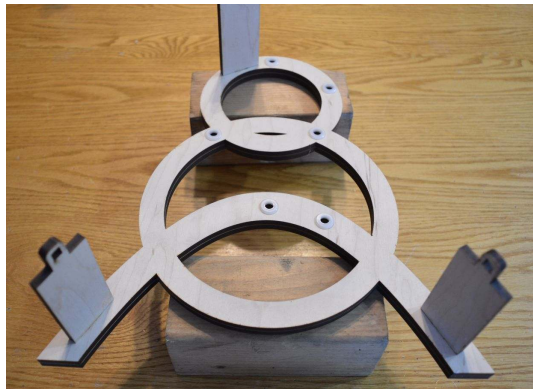

- 2) Make sure that a spacer washer is on the 30-tooth gear shaft and insert into the hole in the front frame as shown below.

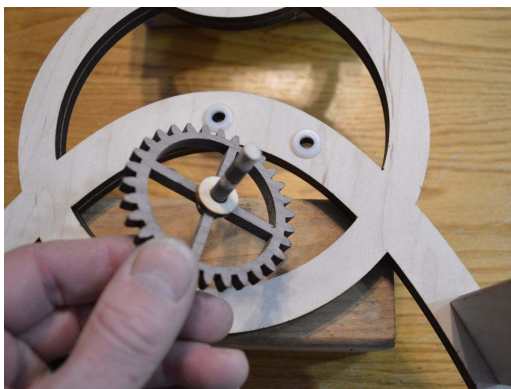

3) On the 60-tooth gear unit, make sure that a spacer washer is is next to the 10-tooth cannon gear. Insert into the center hole in the front frame so that the 10-tooth cannon gear engages with the 30-tooth gear.

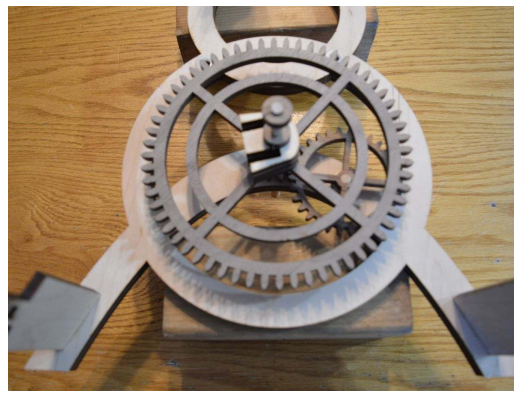
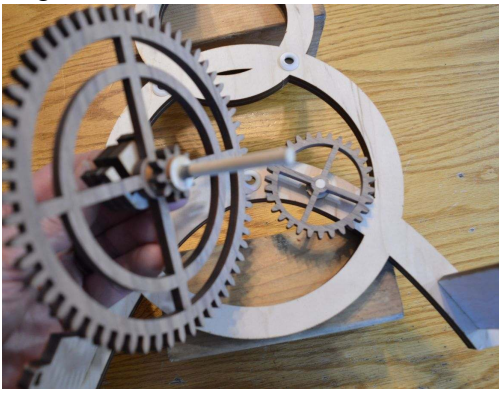

4) Insert the 57-tooth gear into the next hole in the front frame with the smaller gear engaging with the 60-tooth gear. Make sure a spacer washer is on top of the 57-tooth gear.

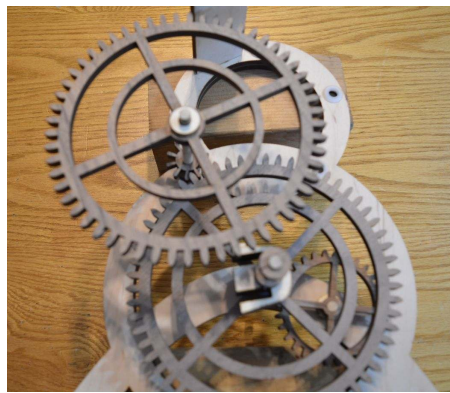

5) Insert the escape lever unit into the topmost hole in the frame as shown below.

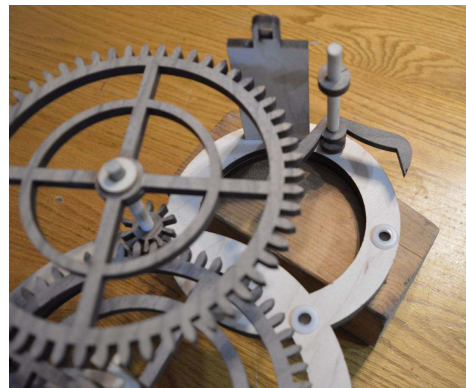

6) Insert the escape wheel unit into the frame. The escape wheel teeth engage with the escape lever teeth.

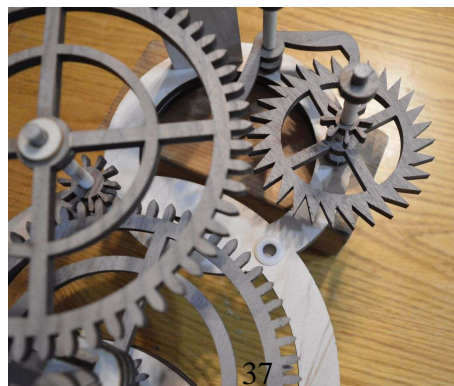

7) Insert the 40-tooth gear unit into the remaining hole in the frame. The 40-tooth gear engages with the 8-tooth escape wheel gear and the 12-tooth gear engages with the 60-tooth gear. Make sure a spacer washer is on top of the 12-tooth gear.



8) With the holes oriented as shown below, guide the two lower pillar tabs into the holes in the bottom part of the rear frame.

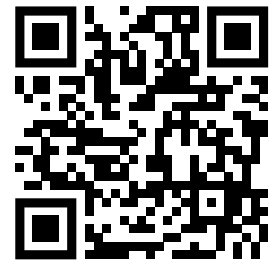
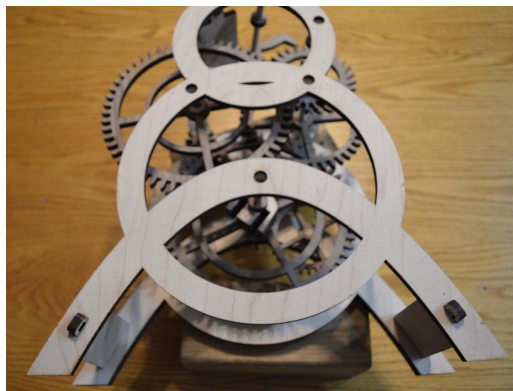

Scan or visit [Wooden-Gear-Clocks.com/i6](http://Wooden-Gear-Clocks.com/i6) to watch of video of steps 8-11

9) Start two of the wedges into the holes in the pillar tabs. Do not push them through all the way yet.

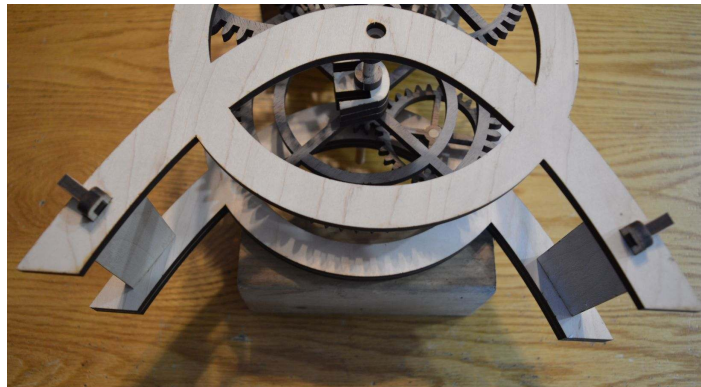

10) Guide the top pillar tab and escape lever dowel so they are started into their holes in the rear frame.



11) Maintain a slight downward pressure on the gear frame while carefully lining up the remaining four dowels so they engage in their holes in the rear frame. Once all five dowels and three pillars are into their rear frame holes, press the three wedges into the pillar slots to tightly secure the rear frame.

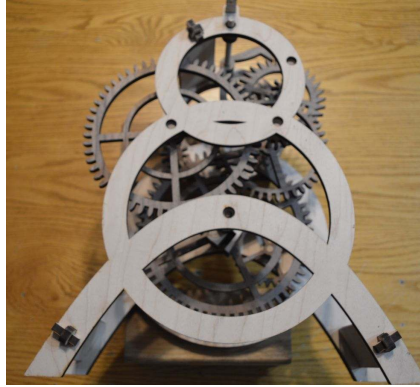

12) Stand up the clock. Verify that the gears are all engaged properly with each other. If necessary, adjust the locations of the set washers so the gears line up and there is a small amount of clearance to permit each gear unit to move within the frame.

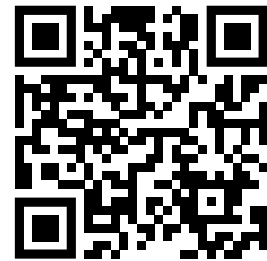

Scan or visit [Wooden-Gear-Clocks.com/i8](http://Wooden-Gear-Clocks.com/i8) to watch of video of step 12

13) Twist a set washer onto the 60-tooth gear shaft. **Leave about 1/16" of clearance between the set washer and the frame.**

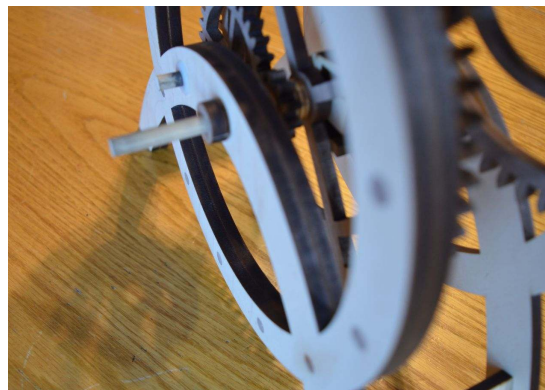

14) Place two small spacer washers onto the 30-tooth gear dowel. Then carefully twist the 8-tooth hour hand gear (#36) onto the dowel. Leave a small amount of clearance so the gear unit is free to rotate (if the 8-tooth gear is loose it can be glued to the dowel).



15) Slide the 32-tooth gear unit onto the dowel, engaging the teeth with the 8-tooth gear. Twist a set washer onto the dowel, leaving a small amount of clearance so the 32-tooth gear is free to rotate on the dowel



16) Twist the minute hand onto the dowel. The fit should be tight enough that the hand maintains its position, but not so tight that it can't be repositioned on the dowel. It might take some light sanding or building up with a thin layer of glue to adjust the fit of the minute hand. (Note: two sets of hands are supplied so you can install hands that match the frame wood or the gear wood; alternatively, you may choose to paint the hands.)

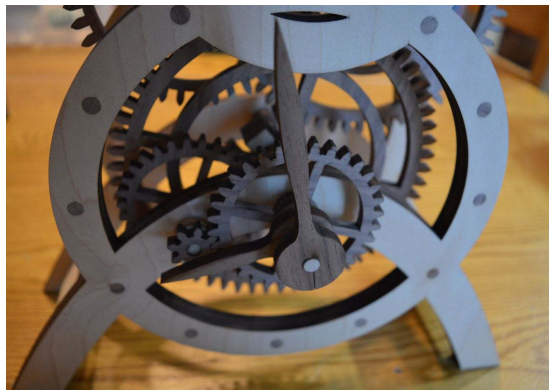

17) Twist the crutch onto the escape lever dowel protruding from the rear frame.



18) Hang the pendulum from the support wire with the solid face of the bob facing the front of the clock. As the shaft drops into place, be sure the crutch pin falls into the slot in the pendulum shaft.



19) While looking at the back side of the clock, apply slight downward force on the 60-tooth gear to give it a counterclockwise rotation. Adjust the crutch position (rotating it slightly on the dowel while holding the escape lever) until the pendulum swings back and forth in response to the torque you are applying to the 60-tooth gear. Make a pencil mark on the end of the crutch's dowel and a corresponding mark on the crutch to "save" this orientation.



Scan or visit [Wooden-Gear-Clocks.com/i7](http://Wooden-Gear-Clocks.com/i7) to watch of video of step 19

20) Remove the pendulum and then remove the crutch. Apply some glue to the hole in the crutch and twist it back onto its dowel, aligning the marks you made. Rehang the pendulum.

21) Once the clock is tested and running, the set washers can be glued in place. Mark the set washer location on the dowel. Twist the set washer over about 1/4". Use a toothpick to apply a small amount of glue on the dowel where the set washer will be. Twist the set washer back into place. It is important to use the glue sparingly so none squeezes out and gets into the nylon shoulder washer.

It would be best to NOT glue the two set washers on either side of the hour gear unit. This will permit disassembly in the future. If these washers are loose, add a thin layer of glue to the dowel and allow to dry before twisting the set washer back into place.

# Weight Arm Installation

## Parts

- 1 - Clock (assembled previously)
- 1 - Weight arm (assembled previously)
- 1 - Weight arm clasp (#49)
- 1 - AA battery

## Procedure

1) Insert the fourth battery into the battery holder in the weight arm. Keep the arm tipped up so the motor doesn't turn.

2) The end of the weight arm fits into the weight arm end. The weight arm must be installed with the protruding tab up. Rotate the weight arm end so it is at an upward angle as shown below. Push the nylon washer up against the 60-tooth gear. Slip the weight arm into the weight arm end (the nylon washer fits between the weight arm front and the 60-tooth gear). Press the pieces together until fully engaged.

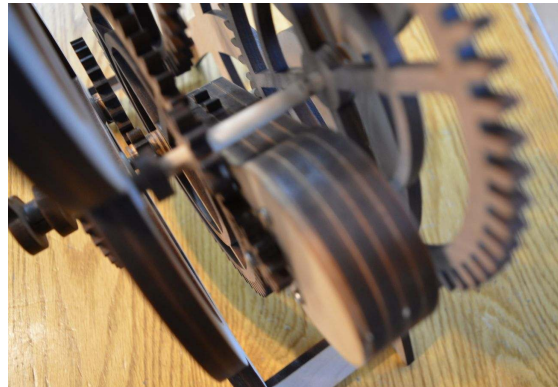
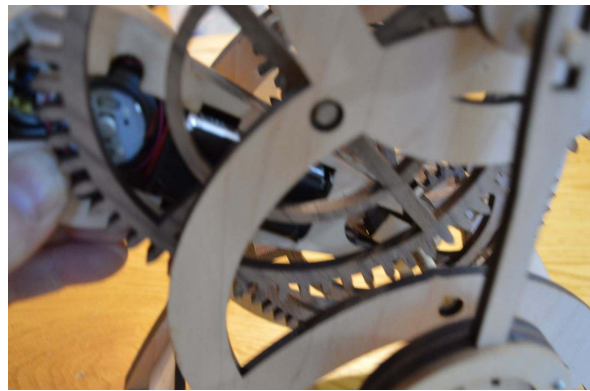

3) Place the weight arm Clasp over the two tabs on the weight arm. You might need to use a screwdriver or pliers to help get the weight arm clasp into position.

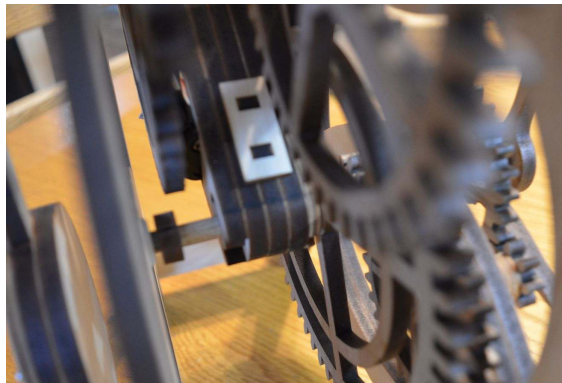

# Adjusting and Regulating

## 1) Setting the clock in beat

In order to run, the clock must be “in beat”. That means that the escape lever moves back and forth at a balanced, even ‘tick-tock’. It should sound like equal gaps between the ticks and tocks as opposed to an uneven ‘galloping’ sound.

The beat is set by rotating the disk on the end of the crutch. Once the correct position is found, the machine screw can be tightened fully so the disk remains in the correct position.

TIP: To determine which way to rotate the disk, lift up one side of the clock or the other to bring the clock into beat. Whichever side you had to lift to bring it into beat is the direction that the crutch pin needs to move.



Scan or visit [Wooden-Gear-Clocks.com/i9](http://Wooden-Gear-Clocks.com/i9) to watch of this process

## 2) Weight Arm Travel

The weight arm should ‘live’ around a horizontal position. If the weight arm moves up or down too far, its travel can be adjusted. Carefully move wires aside and use the tilt switch adjustment tool (#50) or a wide flat blade screwdriver to rotate the tilt switch holder. Rotate the tilt switch holder clockwise to increase downward travel of the weight arm, counterclockwise to increase upward travel.



## 3) Setting the time

The hour and minute hands need to be set independently. Both hands should be friction fit on their shafts so that they can be rotated. If the hands fit too tightly, it may be necessary to grasp the great wheel when setting the hands to prevent the entire motion train from moving. After positioning the hands, verify that neither hand was inadvertently angled inward or outward so that it rubs on or interferes with the other hand or with the gear on the front of the clock.

## 4) Regulating the clock

The nut on the bottom of the pendulum is used to adjust the pace of the clock. To make the clock run faster, turn the nut counterclockwise (as viewed from above). This raises the pendulum bob. Do the opposite to make the clock run slower. Since the clock is made of wood, absolute accuracy cannot be expected, especially with variations in temperature and humidity. With patient adjusting, you should be able to get the clock to be accurate  $\pm 1$  minute per day.

## 5) Changing the batteries

To change the batteries, reverse the process of mounting the weight arm:

Remove the clasp (a flat screwdriver works well for this).

Pull the weight arm away from the weight arm end.

Pry out the battery holder.

Remove and replace the batteries.

Push the battery holder back in, remount the weight arm, and install the clasp.

# Troubleshooting

If the clock fails to operate properly, refer to the suggestions below.

## **Gear Train Will Not Advance**

If the gear train will not advance, first make sure the clock is in beat. If it is in beat but still stops, check the following:

Friction between arbors and bearings

The arbors must spin freely in the nylon bearings. Check to see that the arbors have been sanded smooth where they contact the bearings. Additional sanding may be necessary if the arbors are too tight in the bearings.

Play in gear arbors

There must be a small amount of play in each of the arbors. There should be about 1/16" of free play so that the arbor can be jiggled back and forth between the frame pieces. If the spacers are pushed too tightly against the nylon bearings so that no back and forth movement is allowed, move one of the gears inward on the arbor to allow a small space between the spacers and the nylon bearings.

Gear alignment

Check to see that each gear is aligned with its mating gear. Reposition gears on the shaft as necessary so that mating gears fall in line with each other.

Gear tooth obstruction

Inspect the gear teeth to be sure that each tooth is clean and free of burrs, shards, or stain/varnish build up.

## **Miscellaneous**

Variations in humidity and temperature can affect the accuracy of your clock.

## **Technical Support**

If you have any problems with this clock, please contact Jeff Schierenbeck for assistance:

E-mail: [jeff@wooden-gear-clocks.com](mailto:jeff@wooden-gear-clocks.com)

Telephone: 715-955-4104

## **Comments?**

We'd love to hear from you about your experience with the Infinity clock. Please drop us a note if you want to share any thoughts about the clock or if you have any suggestions for improvements

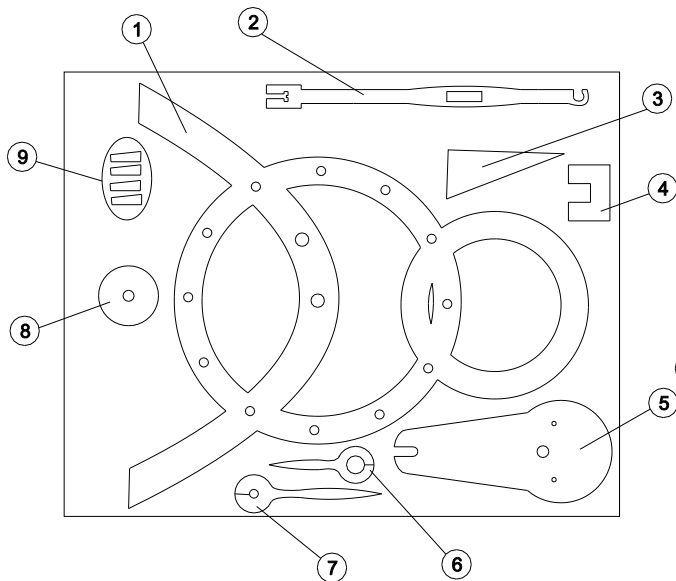

- 1. Front frame front piece
- 2. Pendulum shaft
- 3. Squaring jig
- 4. Pillar jig
- 5. Weight arm veneer piece
- 6. Hour hand (frame wood)

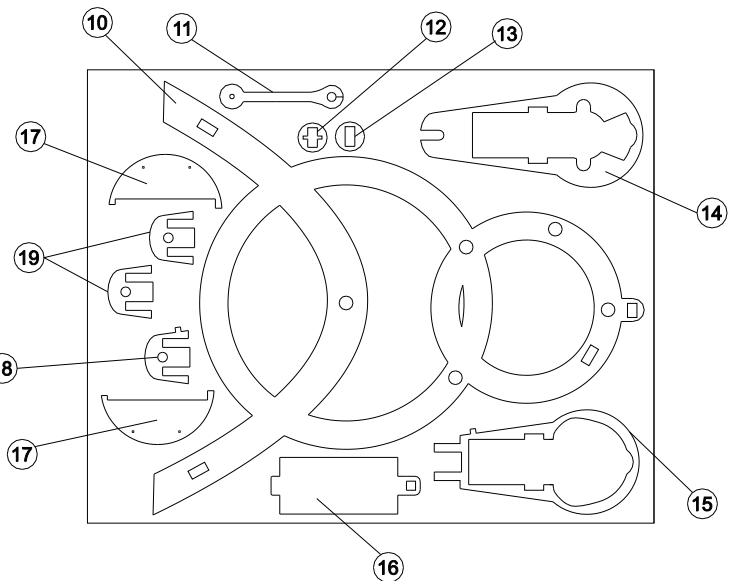

- 7. Minute hand (frame wood)
- 8. Gear staking jig
- 9. Wedges [3]
- 10. Rear Frame
- 11. Crutch arm
- 12. Tilt switch holder top
- 13. Tilt switch holder bottom
- 14. Weight arm back
- 15. Weight arm second layer
- 16. Pillar [3]
- 17. Pendulum bob middle [2]
- 18. Weight arm end middle piece
- 19. Weight arm end outer piece [2]

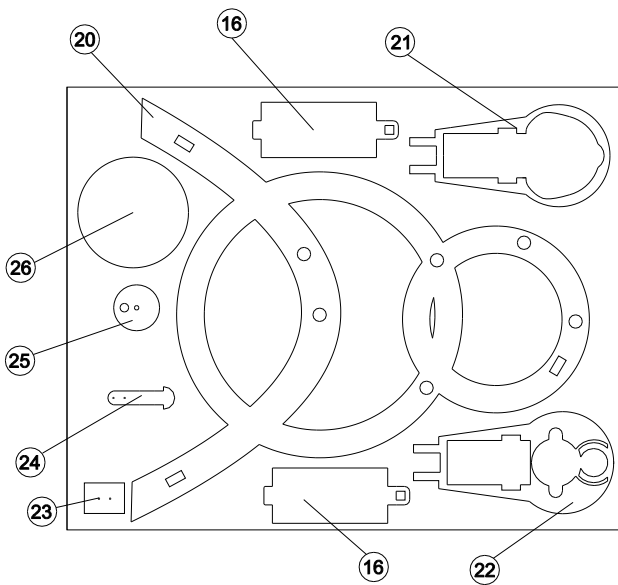

- 20. Front frame back piece
- 21. Weight arm third layer
- 22. Weight arm first layer
- 23. Wire bending jig
- 24. Pendulum support
- 25. Crutch end disk
- 26. Pendulum bob front

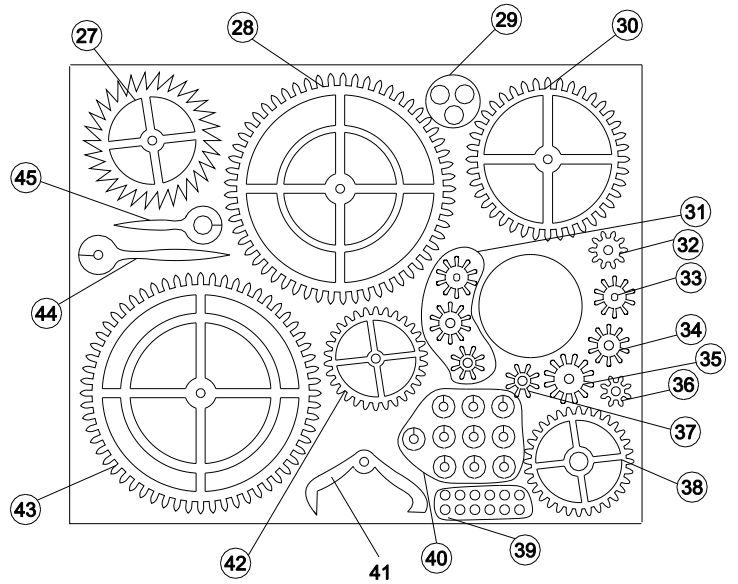

- 27. Escape wheel
- 28. 57-tooth gear
- 29. Hour pipe piece [3]
- 30. 40-tooth gear
- 31. Spare gears
- 32. 10-tooth cannon gear
- 33. Drive gear
- 34. 10-tooth gear
- 35. 12-tooth gear
- 36. 8-tooth hour hand gear
- 37. 8-tooth gear
- 38. 32-tooth gear
- 39. 5-minute markers [12]
- 40. Set washers [10]
- 41. Escape lever
- 42. 30-tooth gear
- 43. 60-tooth gear
- 44. Minute hand (gear wood)
- 45. Hour hand (gear wood)

- 46. Pendulum bob back
- 47. Spacer washers [6]
- 48. Weight arm front
- 49. Weight arm clasp

- 50. Tilt switch adjustment tool
- 51. Small spacer washers [2]

